

FIVE STAR REDEMPTION

OCTOSCORE

MEGA SINGLE PLAYER TECHNICAL MANUAL

January 20, 2016



Features

- Bright Attention Grabbing Graphics
- Hot looking Lights
- Exciting Super Fast Skill Stop
- Oversized Highly Reliability Buttons
- Operator Programmable

Specifications

Parameter	Value	Units
Voltage	115	VAC
Frequency	60	HZ
Weight	600	Pounds

Overview

The Octoscore consists of one lighted clock face with a motorized spinning disk, a player console with large buttons & levers, numeric displays for game play, speakers for sound effects, two coin acceptors, and a ticket dispenser. The objective is to skillfully stop the spinning disks so the player can attempt to accumulate points.

TABLE OF CONTENTS

<i>Features</i>	1
<i>Specifications</i>	1
<i>Overview</i>	1
TABLE OF CONTENTS	2
<i>Game Play</i>	4
<i>Program Mode</i>	5
Changing Program Values	5
Resetting the Statistics & Calibrating the Eight Arrows	10
Diagnostics 71 – 78	11
Steps 71 – 78 Calibrating The Eight Arrows	11
Troubleshooting Steps for Diagnostics 71 - 78	11
Spinner Factory Diagnostics 79.....	12
Checking Spinner Motor, and Brake	12
Troubleshooting Steps for Diagnostic 79	12
Running Diagnostics 80	12
Display Keypad Inputs	12
Running Diagnostics 81	13
Testing Ticket Dispenser	13
Troubleshooting Steps for Diagnostic 81	13
Running Diagnostics 82	13
Testing for Spinner Intermittent Problems	13
Troubleshooting Steps for Diagnostic 82	13
STEP 99 Viewing Software Version	14
View and Changing Spinner Target Values	15
Viewing and Changing Spinner Target Values Steps 100 – 126.....	15
<i>Resetting Game to Factory defaults</i>	20
<i>Top Level Interconnect Diagram</i>	21
GAME PICTORIAL	22
CONTROL MODULE	23
CONTROL MODULE (CONT)	24
CONTROL MODULE (CONT)	25
CONTROL MODULE (CONT)	26
CONTROL MODULE (CONT)	27
CONTROL MODULE (CONT)	28
CONTROL MODULE (CONT)	29
TICKET DISPENSING MODULE	30
TICKET DISPENSING MODULE (CONT)	31

<i>SPINNER MODULE</i>	32
<i>SPINNER MODULE (CONT)</i>	33
<i>SPINNER MODULE (CONT)</i>	34
<i>MISCELLANEOUS WIRING</i>	35
<i>MISCELLANEOUS WIRING (CONT)</i>	36
<i>MISCELLANEOUS WIRING (CONT)</i>	37
<i>OPTO SENSORS WIRING</i>	38
<i>OPTO SENSORS WIRING (CONT)</i>	39
<i>Display and Keypad Wiring</i>	40
<i>Display and Keypad Wiring (cont)</i>	41
<i>Display and Keypad wiring (cont)</i>	42
<i>W1, W2, W3, W7 (13.7 VDC Power Supply and Grounds)</i>	43
<i>W101, W102, W109 (Protective Ground Wiring)</i>	44
<i>Appendix A—VTMUX Board Layout</i>	45
<i>Appendix B—Opto Board Layout</i>	46
<i>Appendix C Troubleshooting Assistance</i>	47
<i>Troubleshooting Guide</i>	47
<i>Appendix D Replacing or Realigning Spinner Wheels</i>	50
<i>Appendix E</i>	53
<i>Technical Assistance</i>	53
<i>Five Star Redemption</i>	54
8803 Shirley Avenue	54
Northridge, CA 91324	54
(818) 773-6057 Fax (818) 773-6064	54
Parts Department Option 1	54
Technical Support Option 2	54
Sales Department Option 3	54

Game Play

Octoscore offers very fast and interesting play with many different strategies for maximizing the points you can win.

The *Spinner* allows the player to accumulate points to win tickets.

- 1) Insert coin(s) to ready the game for play.
- 2) Pull back the *Start Lever* to begin the *Spinner Spinning*.
- 3) There are several seconds in which to influence where the *Spinner* will stop by skillfully pushing the *Slow Stop* button which decreases spinner speed or pulling back on the *Start Lever* which will increase the spinner speed.
- 4) Points are awarded and displayed each time the *Spinner* is spun.

Program Mode

Changing Program Values

Program Mode allows the Game Operator the option of programming the Game by entering data through the Control Panel, which is located on the front panel of the cabinet. This mode includes viewing the game's statistical data, running diagnostics, and changing game play values.

To go into *Program Mode*, Hold Down both the "*" and "#" symbols for approximately 5 seconds the Keypad Display should go Blank, next enter the number "11" which will allow the game operator to go into *Program Mode* (Keypad should display all zero's).

Pressing the **ARROW #5** will decrement the Value, Pressing the **ARROW #8** will increment the value. To increase the **STEP NUMBER** use the Numeric Keypad and press the "*", to decrease the **STEP NUMBER** press the "#" symbol. To Go to **STEPS** directly Hold down the "*" key while entering the **STEP NUMBER** in the keypad. Pressing the *Program Mode* or Holding Down both the "*" and "#" symbols will allow the operator to exit. The program button is located near the main board inside of the cabinet.

Button and display operation with miscellaneous settings (steps 00-68)

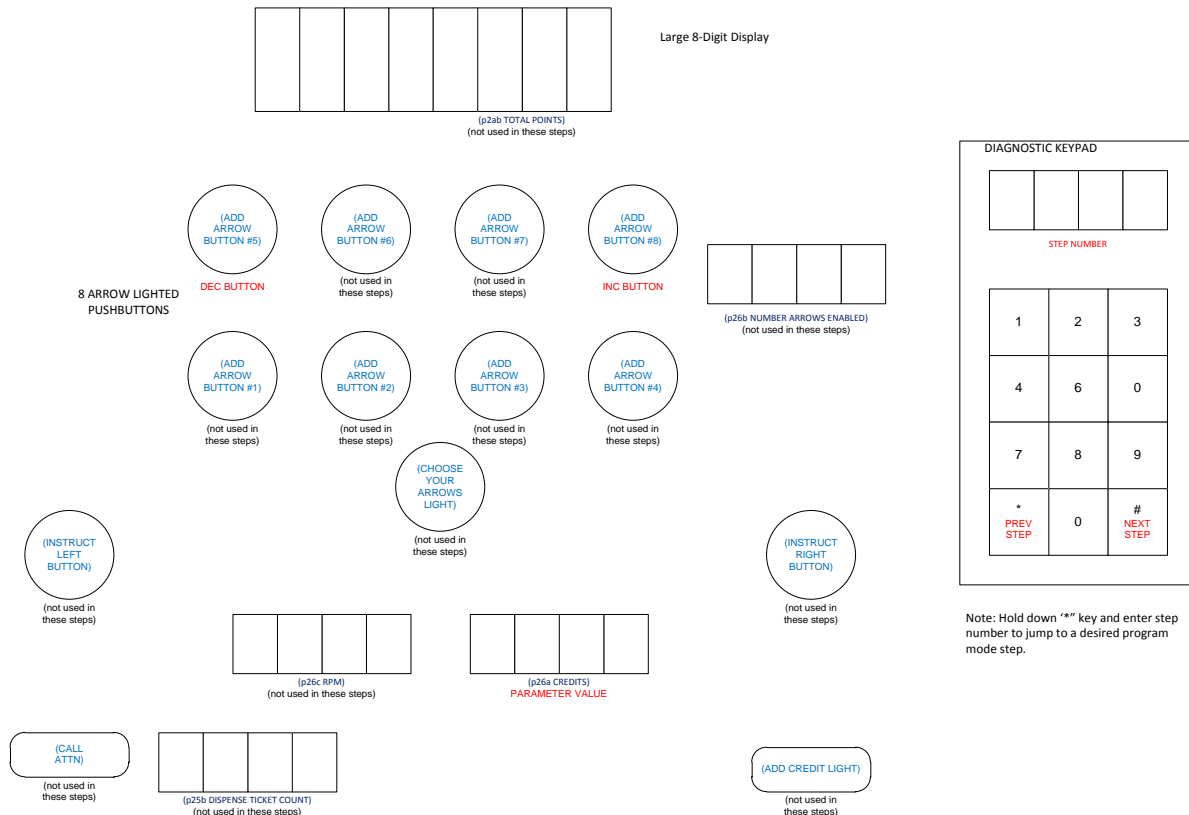

Changing Program Values (cont)

Misc Settings Steps 00 – 29

Description	Step Number	Range (units)	Default Value	Comments
Misc settings				
coins required to play	00	1 – 4	1	Number of coins required to play
attraction audio on time	01	0 - 180 sec	180	Number of seconds attraction audio is on per attraction cycle (0 disables attraction audio)
attraction audio off time	02	0 - 180 sec	0	Number of seconds attraction audio is off per attraction cycle
spinner enable stop rpm1	03	1 - 600	70	Spinner #1 RPM above which stop lever can cut motor power (increments of 1)
spinner enable stop dither1	04	0 - 100	7	Spinner #1 RPM dither before enabling cutting motor power during ramp up (increments of 1)
spinner cruising rpm1	05	30 - 200	100	Spinner #1 cruising RPM (increments of 5)
spinner max hyper rpm1	06	100 - 600	300	Spinner #1 maximum hyperspeed RPM (increments of 5)
spinner maximum time1	07	5 - 30 sec	24	Maximum time before hyper is removed from spinner #1 motor (increments of 1)
number points per ticket	08	0 – 255	2	Number of points required per ticket dispensed (increments of 1)
demo mode	09	0,1	0	0=not demo mode, 1=demo mode
enable keypad display	10	0,1	0	0=do not enable keypad display in game mode, 1=enable keypad display in game mode
spinner diagnostic sensitivity	11	1-9	3	Spinner diagnostic sensitivity (1=most sensitive, 9=least sensitivity)
extra games disable	12	0,1	1	0=enable extra games, 1=disable extra games
timeout to spin with credits	13	5-120 sec	25	Time to push Start button before automatically spinning when player has credits (increments of 1)
timeout to spin with no credits	14	5-120 sec	25	Time to push Start button before going to attraction when player has no credits (increments of 1)
spinner allow full power time	15	1 – 5	1	Time spinner must spin before the player can apply full-power to the spinner (increments of 1)
spinner minimum kick rpm1	16	10 – 100	40	Spinner #1 RPM above which player can abort a stop (increments of 1)
spinner maximum kicks1	17	0 – 10	1	Spinner #1 maximum number of kicks allowed (increments of 1)
spinner max kick time1	18	1 – 5 sec	10	Spinner #1 maximum kick time allowed (increments of 1)
spinner add arrows rpm1	19	50 – 300	10	Spinner #1 rpm above which player can purchase arrows (increments of 1)
enable rpm display	20	0,1	1	0=disable rpm display, 1=enable rpm display
enable arrow points display	21	0,1	1	0=disable display of arrow points, 1=enable display of arrow points
enable could have won display	22	0,1	1	0=disable display of additional points, 1=enable display of additional points if all eight arrows bought
biggest arrow bonus points	23	0-1000	0	Bonus points for purchasing arrow with the most points (increments of 1)
disable spinner startup fault	24	0,1	1	0=enable spinner startup fault, 1=disable spinner startup fault
spinner default arrow number	25	1-9	1	1-8=spinner number, 9="spinning" arrow lights (increments of 1)
ladder gives free spin	26	0-2	0	Ladder gives free spin 0=none, 1=first ladder only, 2=all ladders (increments of 1)
jackpot transition level1	27	100-50000	10000	Progressive ladder transition from level 1 to level 2 (increments of 25)
jackpot transition level2	28	100-50000	11000	Progressive ladder transition from level 2 to level 3 (increments of 25)
jackpot transition level3	29	100-50000	12000	Progressive ladder transition from level 3 to level 4 (increments of 25)
jackpot transition level4	30	100-50000	15000	Progressive ladder transition from level 4 to level 5 (increments of 25)
jackpot increment level1	31	1-10	2	Progressive jackpot increment in level 1 (increments of 1)
jackpot increment level2	32	1-10	2	Progressive jackpot increment in level 2 (increments of 1)
jackpot increment level3	33	1-10	2	Progressive jackpot increment in level 3 (increments of 1)
jackpot increment level4	34	1-10	2	Progressive jackpot increment in level 4 (increments of 1)
jackpot increment level5	35	1-10	2	Progressive jackpot increment in level 5 (increments of 1)

Changing Program Values (cont)

Misc Settings Continued Steps 30-53

Description	Step Number	Range (units)	Default Value	Comments
Misc settings (continued)				
maximum number arrows per spin	36	1-8	8	Maximum number of arrows can be purchased per spin (increments of 1)
maximum number rungs per spin	37	1-8	1	Maximum number of rungs can be won per spin (increments of 1)
countdown timer beginning count	38	30-1000	100	Countdown timer beginning count (increments of 1)
speed awarding arrow points	39	1-3	1	1=normal speed, 2=faster speed, 3=fastest speed (increments of 1)
must display all arrows	40	0,1	0	0=all arrows not required to flash, 1=all arrows must flash
disable countdown timer	41	0,1	0	0=enable countdown timer, 1=disable countdown timer
countdown time limit no credits	42	10-300 sec	25	Time player has to add credits when countdown timer is running without credits (increments of 1)
minimum start up pulsing rpm	43	0-255	10	Minimum RPM where MEGA game spinner motor will be pulsed (increments of 1)
bonus points unawarded rungs	44	1-100	20	Bonus points for unawarded rungs (increments of 1)
spinner minimum brake rpm1	45	0-5000	40	Minimum RPM at which spinner brake solenoid may be energized (increments of 1)
spinner maximum brake rpm1	46	0-5000	70	Maximum RPM at which spinner brake solenoid may be energized (increments of 1)
low pieslices brake enable	47	0-5000	400	Low number pieslices required to energize spinner brake solenoid (increments of 1)
high pieslices brake enable	48	0-5000	2500	High number pieslices required to energize spinner brake solenoid (increments of 1)
number arrows for low pieslices	49	1-8	4	Maximum number arrows selected to specify low number of pieslices (increments of 1)
enable attraction with tickets	50	0,1	1	0=cannot return to attraction with tickets remaining, 1=can return to attraction (increments of 1)
disable must play new arrow sound	51	0,1	1	0=required to play new arrow sound, 1=not required to play new arrow sound (increments of 1)
display could won with points won	52	0,1	1	0=display points could have won after awards, 1=display same time as points won (increments of 1)

Changing Program Values (cont)

Progressive Ladder and Point Values Steps 60-68

Description	Step Number	Range (units)	Default Value	Comments
progressive beginning points	60	100-50000	5000	Progressive jackpot beginning points (increments of 25)
progressive maximum points	61	500-50000	10000	Progressive jackpot maximum points (increments of 25)
progressive ladder points1	62	0-50000	10	Progressive ladder #1 points (increments of 25)
progressive ladder points2	63	0-50000	20	Progressive ladder #2 points (increments of 25)
progressive ladder points3	64	0-50000	30	Progressive ladder #3 points (increments of 25)
progressive ladder points4	65	0-50000	40	Progressive ladder #4 points (increments of 25)
progressive ladder points5	66	0-50000	50	Progressive ladder #5 points (increments of 25)
progressive ladder points6	67	0-50000	60	Progressive ladder #6 points (increments of 25)
progressive ladder points7	68	0-50000	70	Progressive ladder #7 points (increments of 25)

Resetting Statistics and Diagnostics Steps 70-99

Description	Step Number	Range (units)	Default Value	Comments
reset statistics	70	na	na	Reset all statistics that are re-settable
calibrate arrow #1	71	na	na	Facilitate calibration and display arrow #1 "pie slice", points, and position number
calibrate arrow #2	72	na	na	Facilitate calibration and display arrow #2 "pie slice", points, and position number
calibrate arrow #3	73	na	na	Facilitate calibration and display arrow #3 "pie slice", points, and position number
calibrate arrow #4	74	na	na	Facilitate calibration and display arrow #4 "pie slice", points, and position number
calibrate arrow #5	75	na	na	Facilitate calibration and display arrow #5 "pie slice", points, and position number
calibrate arrow #6	76	na	na	Facilitate calibration and display arrow #5 "pie slice", points, and position number
calibrate arrow #7	77	na	na	Facilitate calibration and display arrow #5 "pie slice", points, and position number
calibrate arrow #8	78	na	na	Facilitate calibration and display arrow #5 "pie slice", points, and position number
spinner factory diagnostic	79	na	na	Spinner factory diagnostic
keypad [t/o 1]	80	0-255	na	Display keypad inputs
ticket dispenser	81	25-9,975	na	Dispense a ticket from ticket dispenser #1 or ticket dispenser #2
spin spinners/display error count	82	0-255	na	Spin spinners and display error count of binary code miss-reads from spinner encoder
display software ID	99	na	na	8-digit software ID number
spinner offset1,2,3,4,5	na	na	na	(these parameters are automatically set in Steps 71-75)

Note1: Default value varies for different customers.

Changing Program Values (cont)

Target Point Values Steps 100-173

Description	Step Number	Range (units)	Default Value	Comments
target_points (Spinner #1)				
Position #00	100	0-2000		Points at position #00 (increments of 1)
Position #01	101	0-2000		Points at position #01 (increments of 1)
Position #02	102	0-2000		Points at position #02 (increments of 1)
Position #03	103	0-2000		Points at position #03 (increments of 1)
Position #04	104	0-2000		Points at position #04 (increments of 1)
Position #05	105	0-2000		Points at position #05 (increments of 1)
Position #06	106	0-2000		Points at position #06 (increments of 1)
Position #07	107	0-2000		Points at position #07 (increments of 1)
Position #08	108	0-2000		Points at position #08 (increments of 1)
Position #09	109	0-2000		Points at position #09 (increments of 1)
Position #10	110	0-2000		Points at position #10 (increments of 1)
Position #11	111	0-2000		Points at position #11 (increments of 1)
Position #12	112	0-2000		Points at position #12 (increments of 1)
Position #13	113	0-2000		Points at position #13 (increments of 1)
Position #14	114	0-2000		Points at position #14 (increments of 1)
Position #15	115	0-2000		Points at position #15 (increments of 1)
Position #16	116	0-2000		Points at position #16 (increments of 1)
Position #17	117	0-2000		Points at position #17 (increments of 1)
Position #18	118	0-2000		Points at position #18 (increments of 1)
Position #19	119	0-2000		Points at position #19 (increments of 1)
Position #20	120	0-2000		Points at position #20 (increments of 1)
Position_adjustments (Spinner #1)				
Pieslice Adjustment Position #00	150	0-4		Pieslice adjustment at position #00, where value of 2 is no adjustment (increments of 1)
Pieslice Adjustment Position #01	151	0-4		Pieslice adjustment at position #01, where value of 2 is no adjustment (increments of 1)
Pieslice Adjustment Position #02	152	0-4		Pieslice adjustment at position #02, where value of 2 is no adjustment (increments of 1)
Pieslice Adjustment Position #03	153	0-4		Pieslice adjustment at position #03, where value of 2 is no adjustment (increments of 1)
Pieslice Adjustment Position #04	154	0-4		Pieslice adjustment at position #04, where value of 2 is no adjustment (increments of 1)
Pieslice Adjustment Position #05	155	0-4		Pieslice adjustment at position #05, where value of 2 is no adjustment (increments of 1)
Pieslice Adjustment Position #06	156	0-4		Pieslice adjustment at position #06, where value of 2 is no adjustment (increments of 1)
Pieslice Adjustment Position #07	157	0-4		Pieslice adjustment at position #07, where value of 2 is no adjustment (increments of 1)
Pieslice Adjustment Position #08	158	0-4		Pieslice adjustment at position #08, where value of 2 is no adjustment (increments of 1)
Pieslice Adjustment Position #09	159	0-4		Pieslice adjustment at position #09, where value of 2 is no adjustment (increments of 1)
Pieslice Adjustment Position #10	160	0-4		Pieslice adjustment at position #10, where value of 2 is no adjustment (increments of 1)
Pieslice Adjustment Position #11	161	0-4		Pieslice adjustment at position #11, where value of 2 is no adjustment (increments of 1)
Pieslice Adjustment Position #12	162	0-4		Pieslice adjustment at position #12, where value of 2 is no adjustment (increments of 1)
Pieslice Adjustment Position #13	163	0-4		Pieslice adjustment at position #13, where value of 2 is no adjustment (increments of 1)
Pieslice Adjustment Position #14	164	0-4		Pieslice adjustment at position #14, where value of 2 is no adjustment (increments of 1)
Pieslice Adjustment Position #15	165	0-4		Pieslice adjustment at position #15, where value of 2 is no adjustment (increments of 1)
Pieslice Adjustment Position #16	166	0-4		Pieslice adjustment at position #16, where value of 2 is no adjustment (increments of 1)
Pieslice Adjustment Position #17	167	0-4		Pieslice adjustment at position #17, where value of 2 is no adjustment (increments of 1)
Pieslice Adjustment Position #18	168	0-4		Pieslice adjustment at position #18, where value of 2 is no adjustment (increments of 1)
Pieslice Adjustment Position #19	169	0-4		Pieslice adjustment at position #19, where value of 2 is no adjustment (increments of 1)
Pieslice Adjustment Position #20	170	0-4		Pieslice adjustment at position #20, where value of 2 is no adjustment (increments of 1)

DIAGNOSTICS

Resetting the Statistics & Calibrating the Eight Arrows

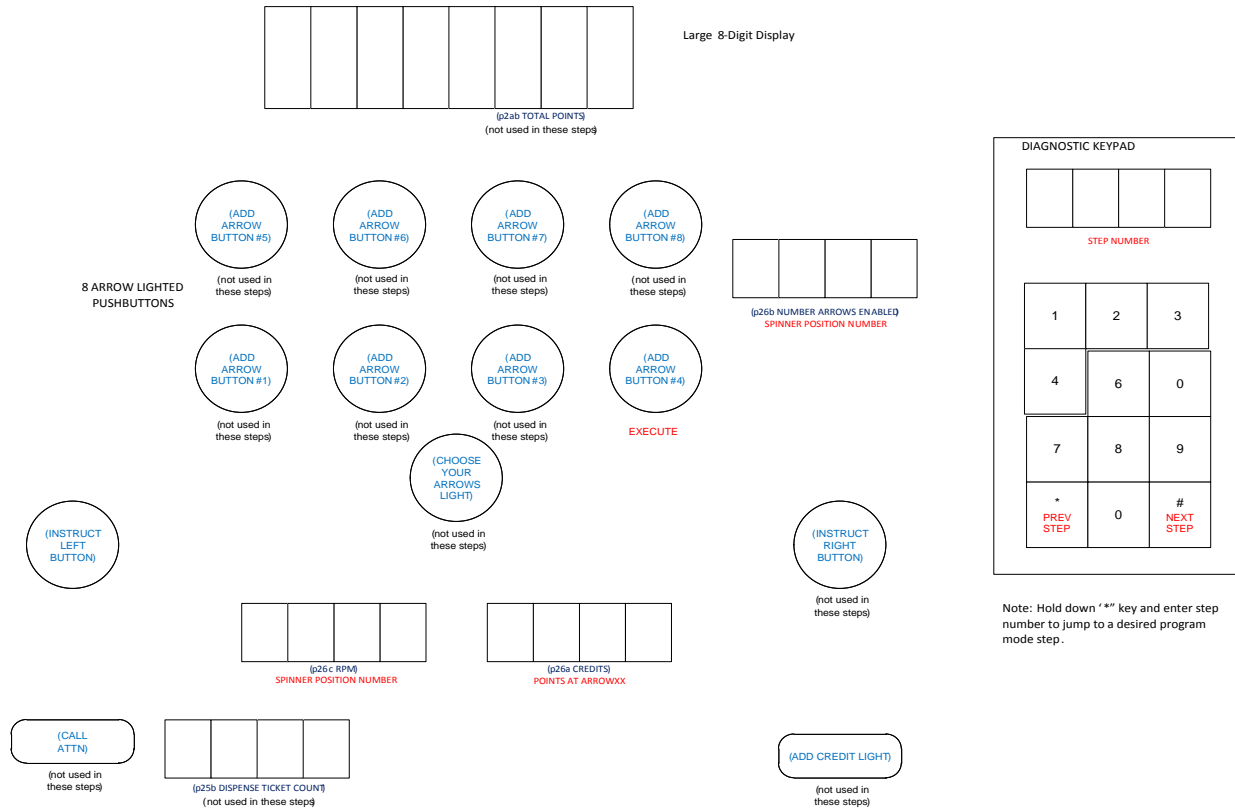

Note: Hold down '*' key and enter step number to jump to a desired program mode step.

Pressing the **ARROW BUTTON #4** will reset the resettable statistics.

STEP #	DESCRIPTION
70	Reset Statistics

DIAGNOSTICS

DIAGNOSTICS STEPS 71 – 78

STEPS 71 – 78 CALIBRATING THE EIGHT ARROWS

Use the SLOW STOP lever to rotate the spinner graphics to the calibration point on the arrow then press the #4 Push Button to calibrate that Arrow. Displays Spinner Information Pie Slices 0-255, Position Type, Points, and Position Number.

Step Number	Arrow Number
71	1
72	2
73	3
74	4
75	5
76	6
77	7
78	8

Troubleshooting Steps for Diagnostics 71 - 78

Problem	Solution
Pie Slice is not zero when spinner is pointing straight to the calibration point.	<ul style="list-style-type: none">Recalibrate to TDC by manually positioning pointer to calibration point and pushing #4 Push Button (spinner may be energized by momentarily pulling the Stop Lever)
Wrong Pie Slice 0-255, Pie Slice number should increase smoothly from 0 to 255 as spinner is rotated clockwise	<ul style="list-style-type: none">Check Encoder Reader BoardExamine/reseat wiring harness connections.
Wrong Position Number, Position Number should increase smoothly from 0 as spinner is rotated clockwise through each Spinner Position	<ul style="list-style-type: none">Examine/reseat wiring harness connections.Recalibrate to calibration point by manually positioning pointer straight up and pressing the #4 Push Button

DIAGNOSTICS

SPINNER DIAGNOSTICS 79

Checking Spinner Motor, and Brake

The number of the selected spinner is shown on the RPM display. Pull the **Stop Lever** to energize the spinner brake and the **Start Lever** to energize the spinner motor. Hold down the **Stop Lever** while Pulling the **Start Lever** to cause the spinner to spin more slowly. Perform the troubleshooting steps in the sequence specified in Troubleshooting Steps for Diagnostic 79 on next page.

TROUBLESHOOTING STEPS FOR DIAGNOSTIC 79

Problem	Solution
Spinner Does Not Spin	<ul style="list-style-type: none">• Examine/reseat wiring harness connections to spinner boards• Look for low-voltage changes at VTMUX board output when spinner should be spinning and if voltage does not change, replace VTMUX board and retest
Particular brake(s) do not activate	<ul style="list-style-type: none">• Verify spinner board switches are set correctly• Examine/reseat wiring harness connections to spinner boards• Adjust/replace spinner brake and retest
Brakes do not activate	<ul style="list-style-type: none">• Examine/reseat wiring harness connections to spinner boards• Look for low-voltage changes at VTMUX board output when brake should be activated and if voltage does not change, replace VTMUX board and retest

RUNNING DIAGNOSTICS STEP 80

Display Keypad Inputs

Push each of the individual numbers on the keypad to display the associated keypad number.

DIAGNOSTICS

RUNNING DIAGNOSTICS STEP 81

Testing Ticket Dispenser

Push the Flashing **Call Attendant Pushbutton** to Dispense a Single Ticket. If you have Dual Ticket dispensers press the **#4 Pushbutton** to go from Ticket Dispenser #1 to dispenser #2 and vice versa.

Troubleshooting Steps for Diagnostic 81

Problem	Solution
Does not dispense tickets	<ul style="list-style-type: none">• Clear ticket dispenser of any jammed tickets• Load tickets if empty• Try dispensing a ticket using diagnostic mode, if ticket does not dispense:<ul style="list-style-type: none">○ Check wiring harness○ Replace ticket dispenser and retest○ Replace VTMUX board and retest

RUNNING DIAGNOSTICS STEP 82

Testing for Spinner Intermittent Problems

Check for spinner intermittent problems while spinners are spinning. Momentarily press keypad 1 to begin test on selected spinner. **Press Keypad 0** to stop test. Perform the troubleshooting steps in the sequence Troubleshooting Steps for Diagnostic 82.

TROUBLESHOOTING STEPS FOR DIAGNOSTIC 82

Problem	Solution
Spinner errors detected (a couple errors during a couple minutes of operation is normal and will not cause problems in game's operation)	<ul style="list-style-type: none">• Examine/reseat wiring harness connections to Spinner Board• Replace Encoder Reader Board• Replace Smart Spinner Board• Replace spinner mechanism and retest

STEP 99 VIEWING SOFTWARE VERSION

Button and Display Operation with Software ID

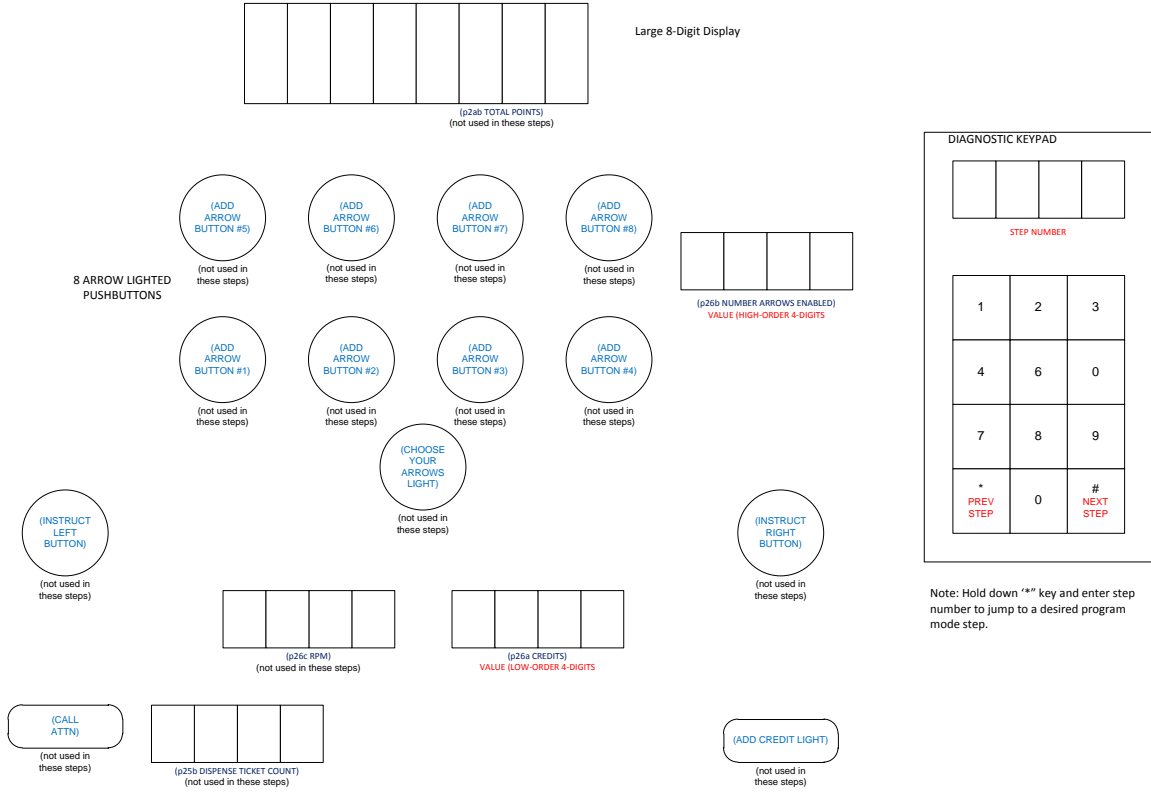

Note: Hold down "*" key and enter step number to jump to a desired program mode step.

View and Changing Spinner Target Values

VIEWING AND CHANGING SPINNER TARGET VALUES STEPS 100 – 126

Pressing the **FAST STOP BUTTON** will decrement the Value, Pressing the **START BUTTON** will increment the value. To increase the **STEP NUMBER** use the Numeric Keypad and press the ‘*’, to decrease the **STEP NUMBER** press the ‘#’ symbol. To Go to **STEPS** directly Hold down the “*” key while entering the **STEP NUMBER** in the keypad. Pressing the *Program Mode* or Holding Down both the ‘*’ and “#” symbols will allow the operator to exit. The program button is located near the main board inside of the cabinet.

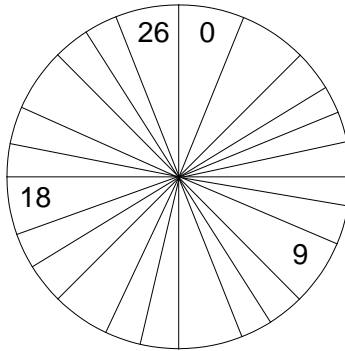

Steps 100 - 126

Viewing Spinner Target Points

STEP NUMBER SPINNER #1	SPINNER POSITION	TARGET POINTS
100	0	INCREMENTS OF 1
101	1	“
102	2	“
103	3	“
104	4	“
105	5	“
106	6	“
107	7	“
108	8	“
109	9	“
110	10	“
111	11	“
112	12	“
113	13	“
114	14	“
115	15	“
116	16	“
117	17	“
118	18	“

STEP NUMBER SPINNER #1	SPINNER POSITION	TARGET POINTS
119	19	“
120	20	“
121	21	“
122	22	“
123	23	“
124	24	“
125	25	“
126	26	“

View and Changing Spinner Target Values

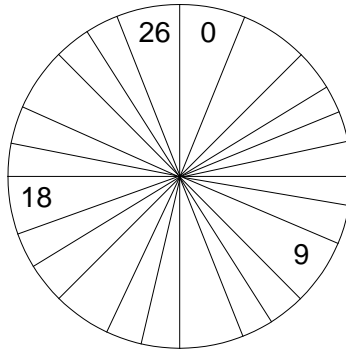

Steps 150 - 176
Changing Spinner Pie Slice Position

Step Number	Spinner Pie Slice Position	Spinner Position
150	0	0 = -2 PIE SLICES 1 = -1 PIE SLICES 2 = NO CHANGE 3 = +1 PIE SLICE 4 = +2 PIE SLICE
151	1	“
152	2	“
153	3	“
154	4	“
155	5	“
156	6	“
157	7	“
158	8	“
159	9	“
160	10	“
161	11	“
162	12	“
163	13	“
164	14	“
165	15	“
166	16	“
167	17	“
168	18	“
169	19	“
170	20	“
171	21	“
172	22	“
173	23	“
174	24	“
175	25	“
176	26	“

VIEWING STATICAL INFORMATION STEPS 700, 701, AND 800

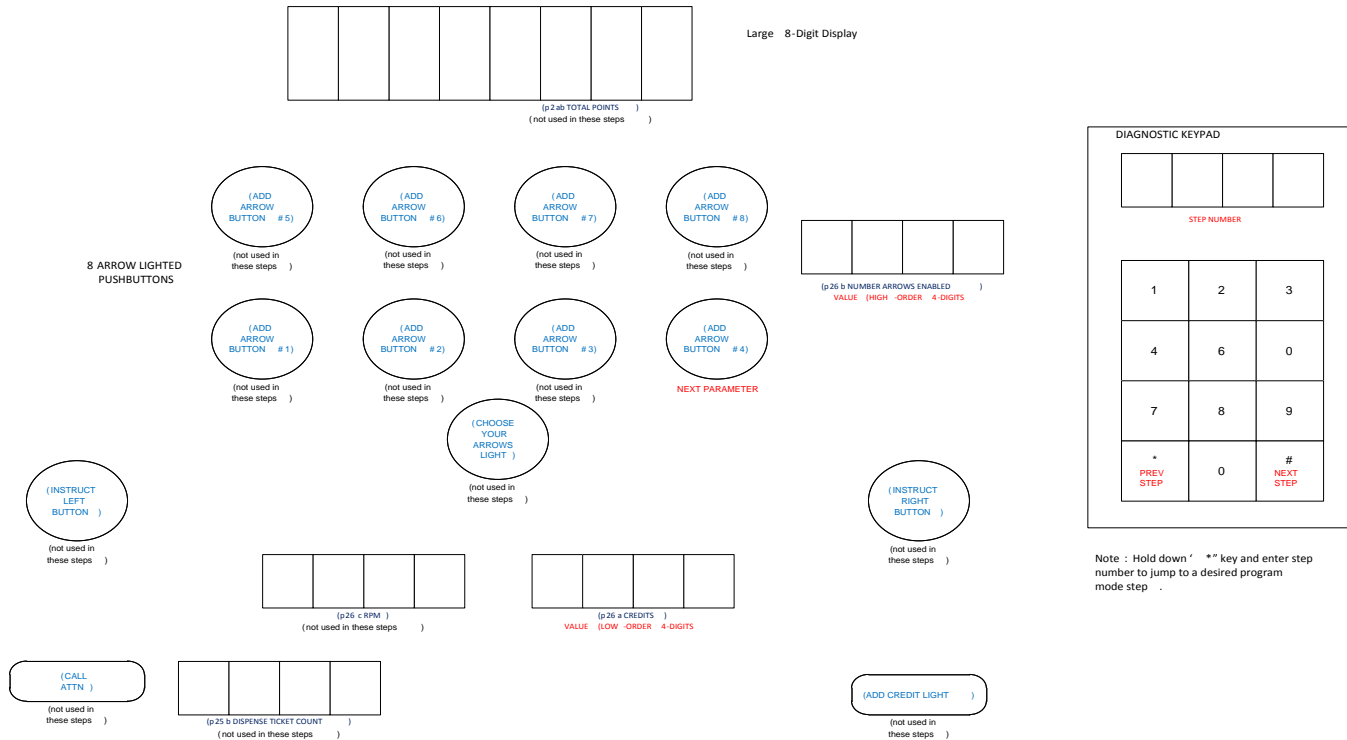

Note : Hold down "*" key and enter step number to jump to a desired program mode step .

To increase the **STEP NUMBER** use the Numeric Keypad and press the "*", to decrease the **STEP NUMBER** press the '#' symbol. To Go to **STEPS** directly Hold down the "*" key while entering the **STEP NUMBER** in the keypad. To View Statistics Press the **#4 BUTTONS** to cycle through each Statistic.

Description	Step Number	Range (units)	Default Value	Comments
Resettable Statistics	700	NA (see comments)	NA	Display the resettable statistics
01=coins			FULL	
02=spins			0	
03=game timeouts		0 - 16,777,216	0	
04= tickets dispensed		0 - 16,777,216	0	
05 =points			Na	
06=spinner tampers		0 - 16,777,216		

Viewing Statistical Information

Description	Step Number	Range (units)	Default Value	Comments
07=spins with 1 arrows purchased 08= spins with 2 arrows purchased 09= spins with 3 arrows purchased 10= spins with 4 arrows purchased 11= spins with 5 arrows purchased 12= spins with 6 arrows purchased 13= spins with 7 arrows purchased 14= spins with 8 arrows purchased Lifetime Statistics 01=coins 02=spins 03=game timeouts 04= tickets dispensed 05 =points 06=spinner tampers 07= spins with 1 arrows purchased 08= spins with 2 arrows purchased 09= spins with 3 arrows purchased 10= spins with 4 arrows purchased 11= spins with 5 arrows purchased 12= spins with 6 arrows purchased 13= spins with 7 arrows purchased 14= spins with 8 arrows purchased	701	0 – 16,777,216	NA	Display the lifetime statistics
Resettable Percent Spins Arrows 01=percent spins with 1 arrows 02=percent spins with 2 arrows 03=percent spins with 3 arrows 04=percent spins with 4 arrows 05=percent spins with 5 arrows 06=percent spins with 6 arrows 07=percent spins with 7 arrows 08=percent spins with 8 arrows	800	0-100	NA	Display the resettable percent spins with 1-8 arrows

Resetting Game To Factory Defaults

Resetting Game to Factory Defaults

1. Turn Power of the Unit Using the Power Strip
2. Turn the power back on while holding in the *Prog Mode Button*, and hold it in for approximately 5 seconds

VTMUX Board Connection Layout

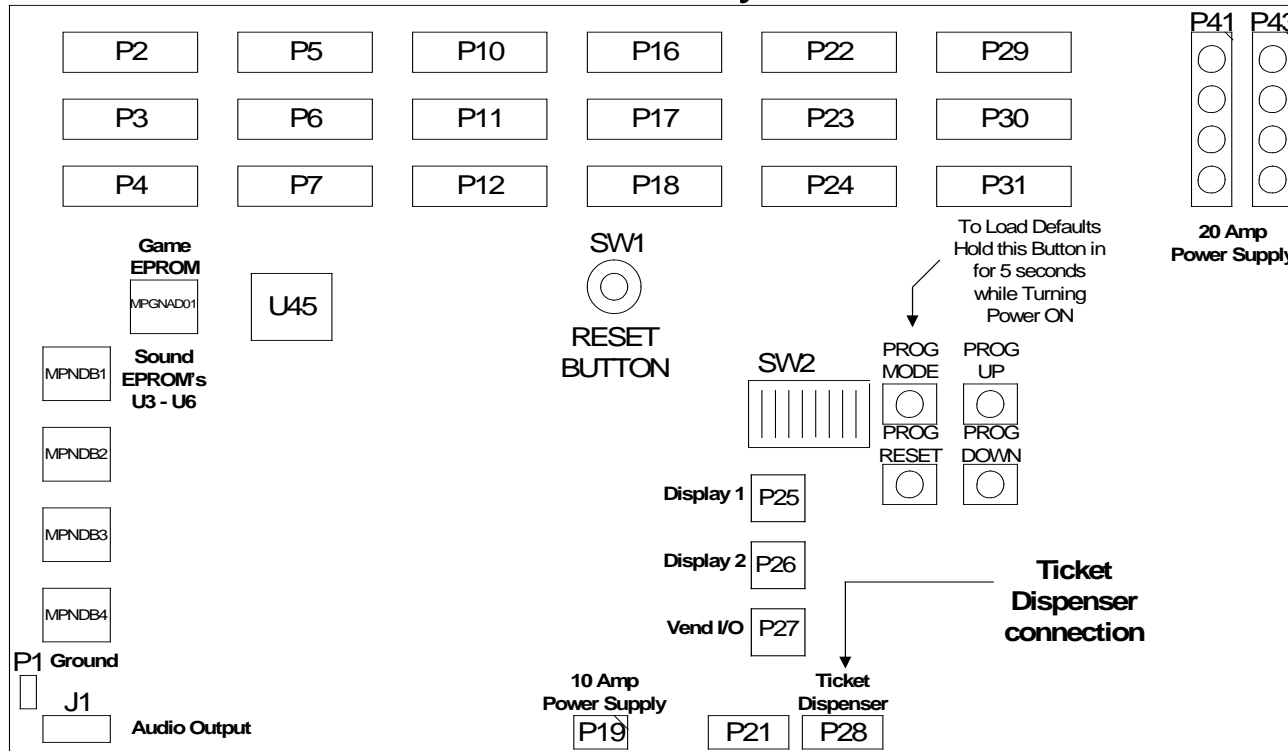

Top Level Interconnect Diagram

TOP LEVEL INTERCONNECT DIAGRAM

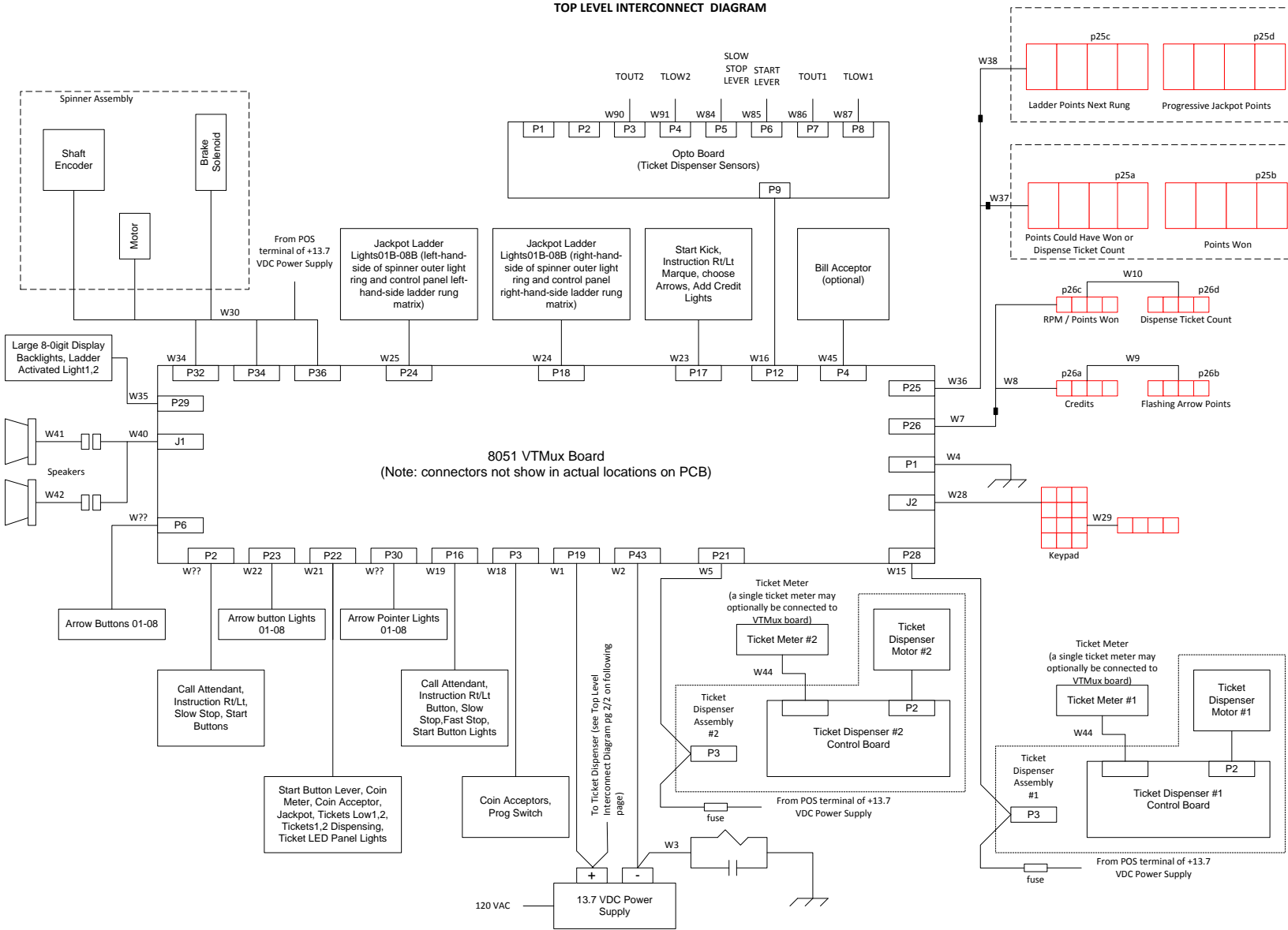

GAME PICTORIAL

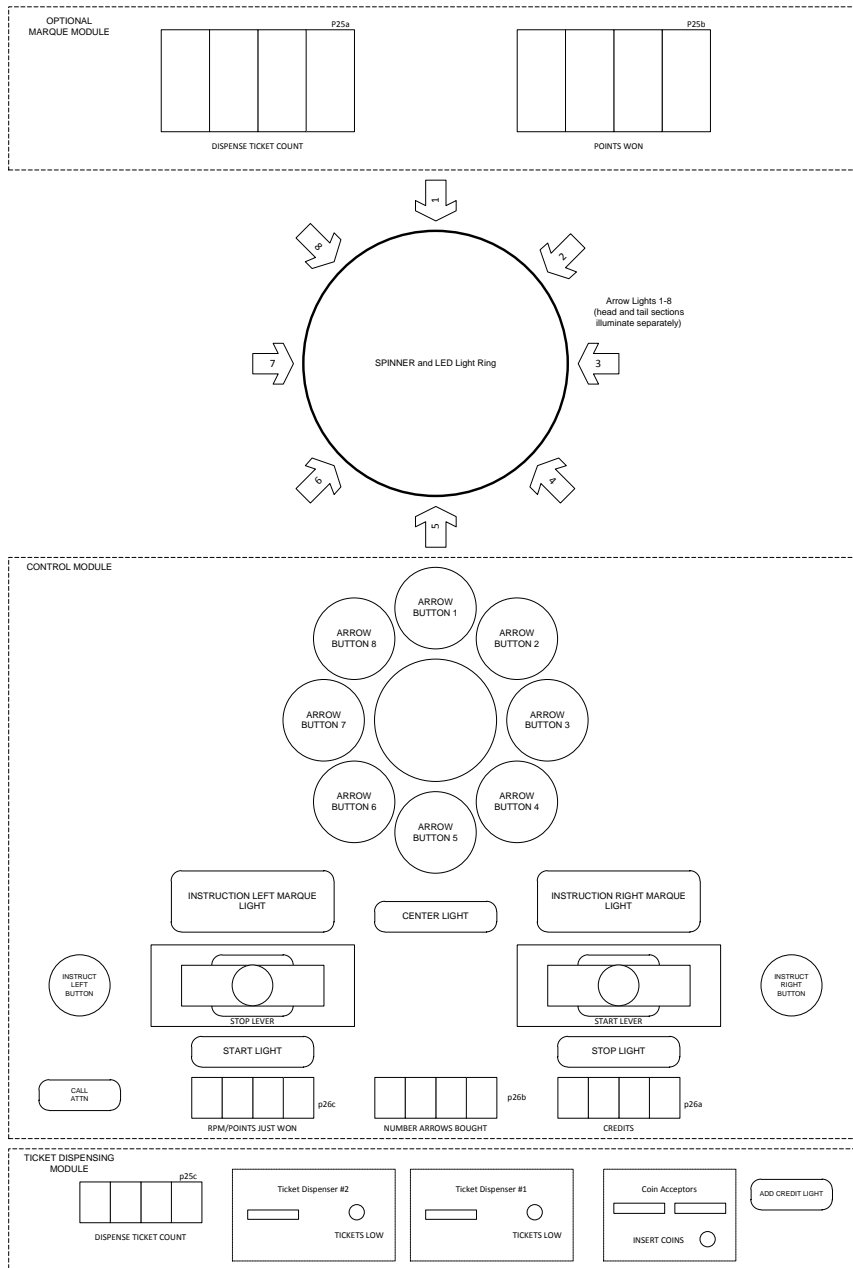

CONTROL MODULE

W23 (VTMUX Board P2, 16, 17 to 36-Pin Molex plug)

W23 (Opto Board P5 to 36-Pin Molex plug)

W23 (Opto Board P6 to 36-Pin Molex plug)

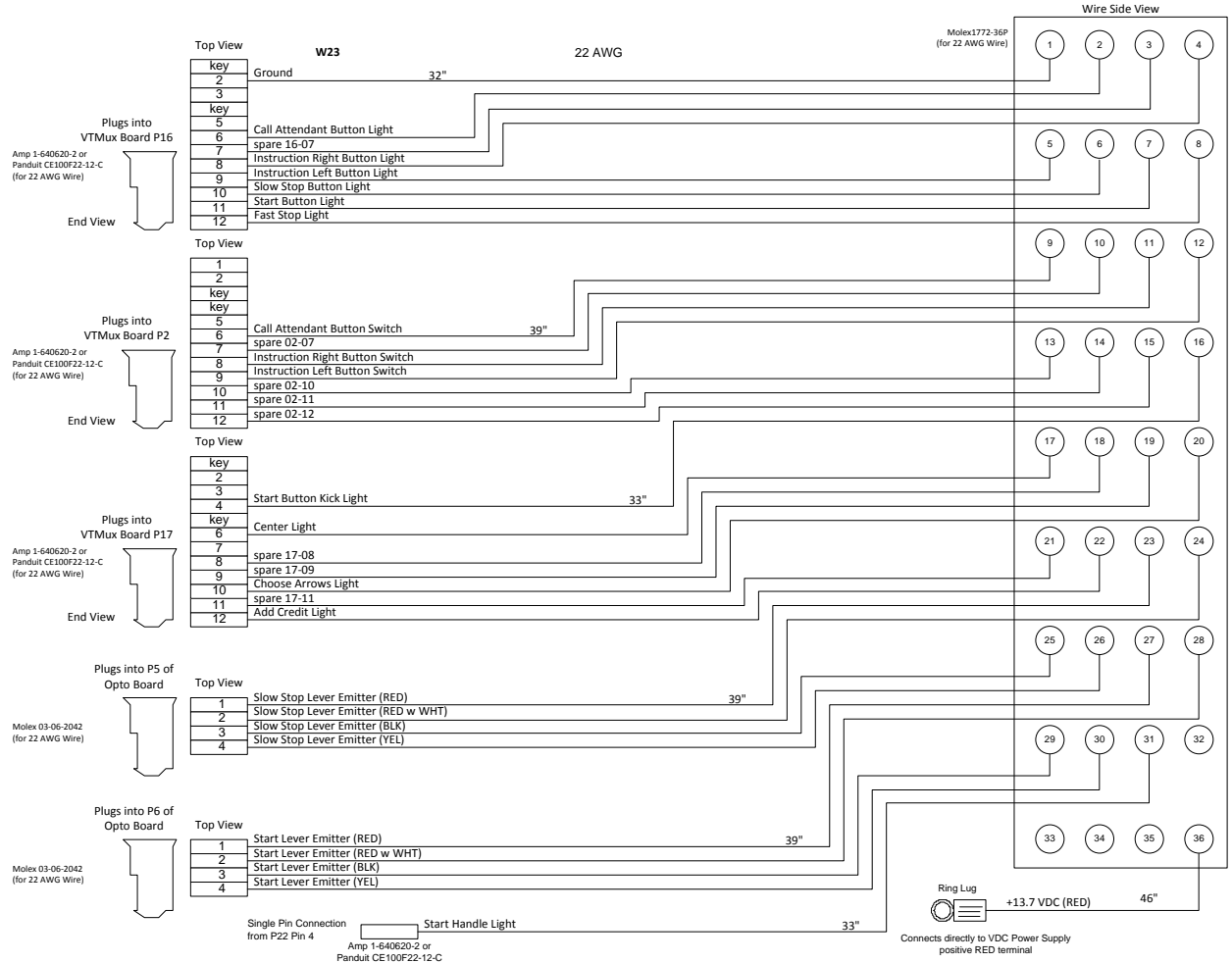

CONTROL MODULE (CONT)

W24 (36-Pin Molex Receptacle to Miscellaneous Control Panel Switches/Lights)

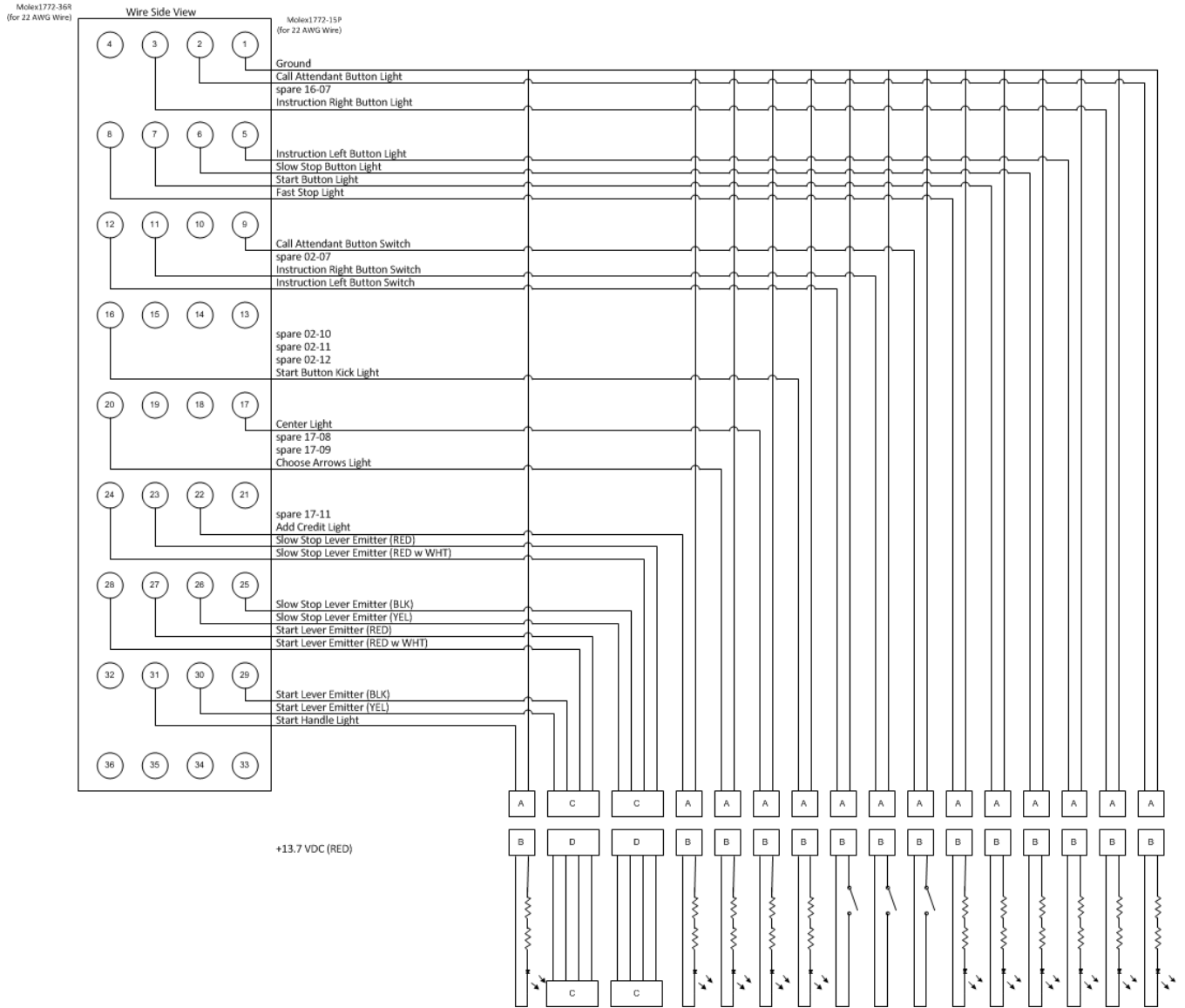

CONTROL MODULE (CONT)

W22 (VTMUX Board P23 to 36-Pin Molex Plug) W25 (36-Pin Molex Receptacle to Arrow Button Lights)

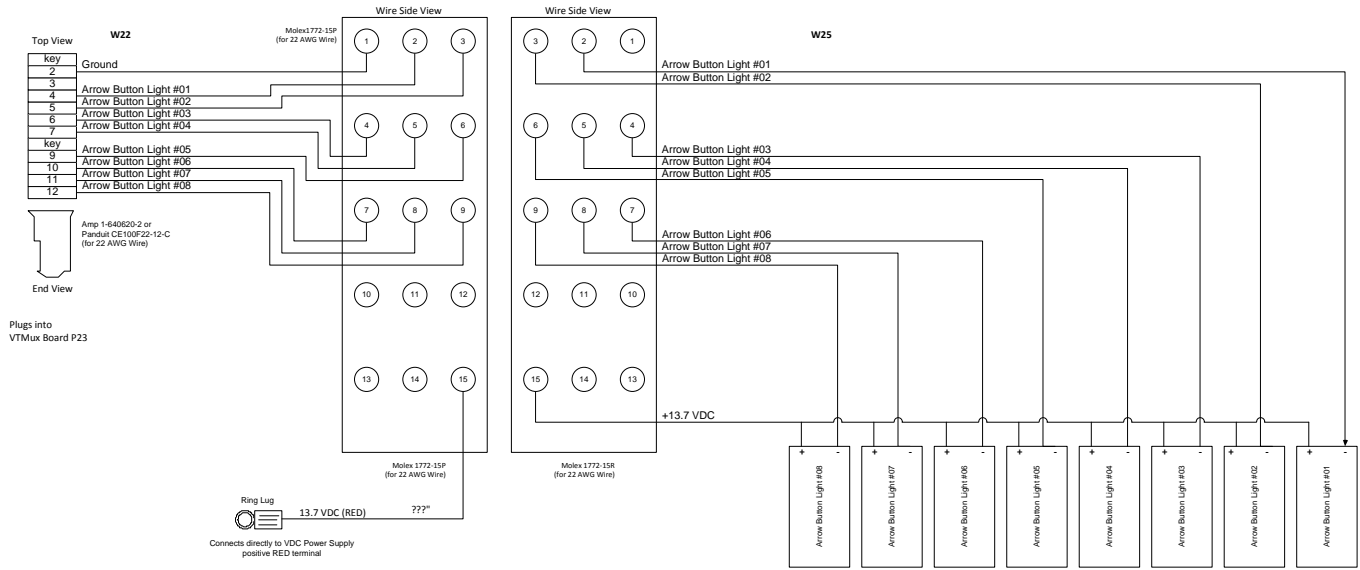

CONTROL MODULE (CONT)

W26 (VTMUX Board P30 to Arrow Head Lights)

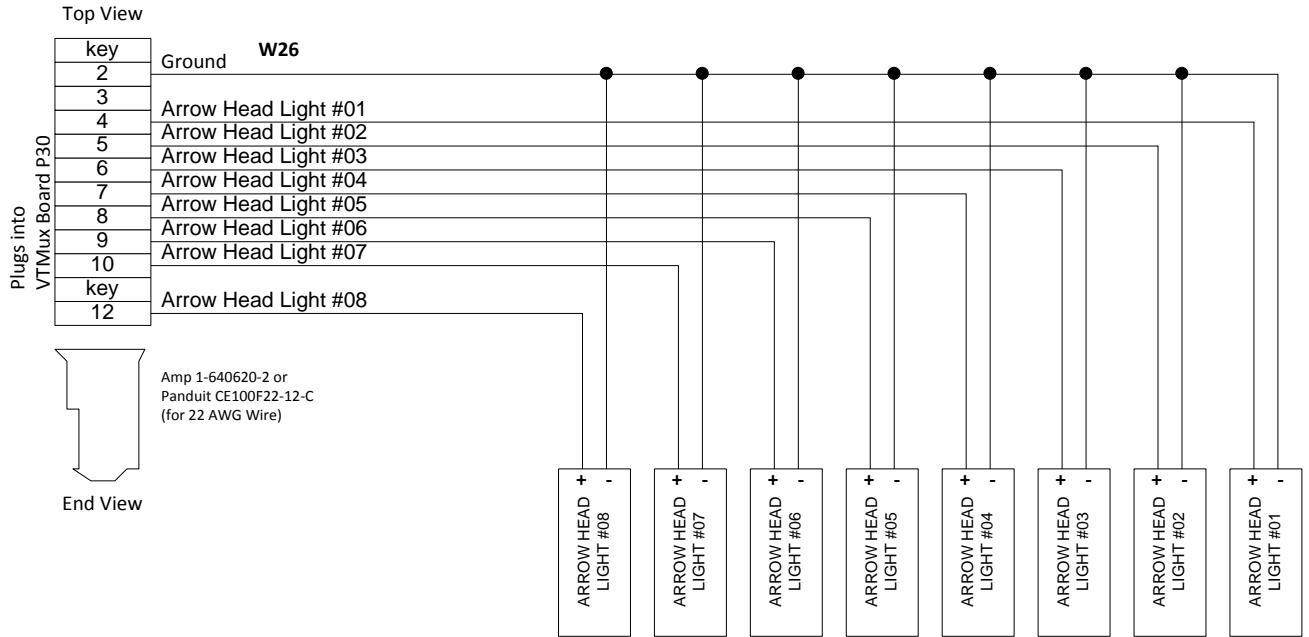

CONTROL MODULE (CONT)

W27 (VTMUX Board P31 to Arrow Base Lights)

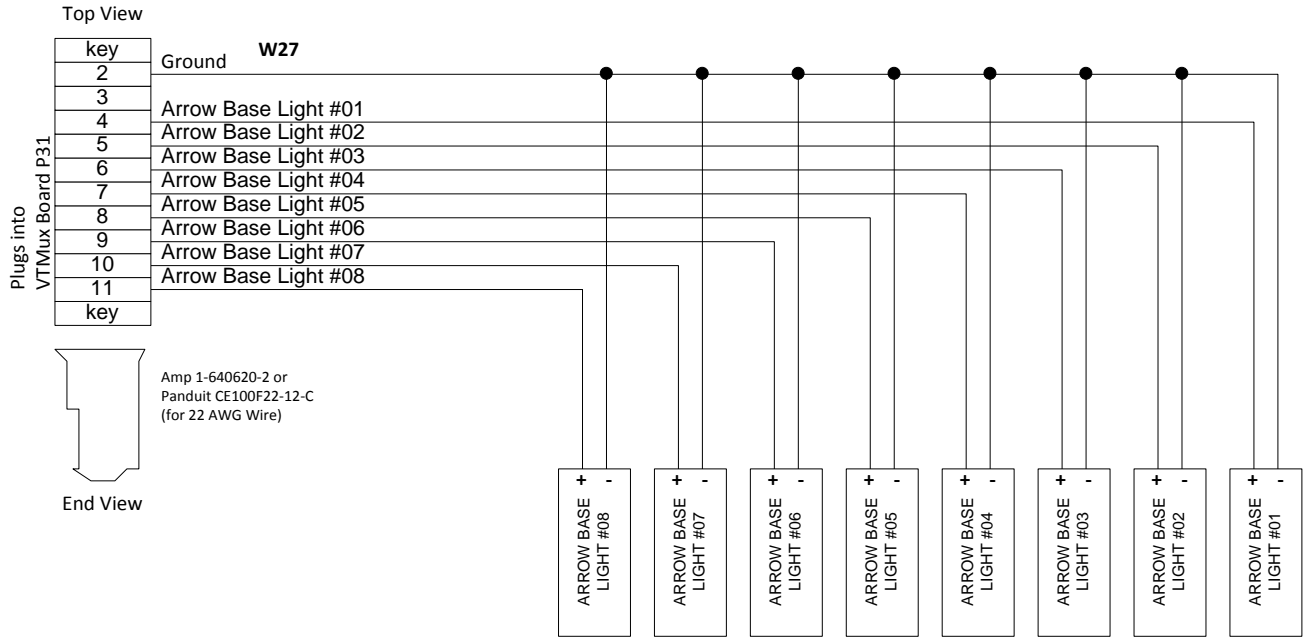

CONTROL MODULE (CONT)

W24 (VTMUX Board P18 to Spinner Ring Lights)

Amp 1-640620-2 or
Panduit CE100F22-12-C
(for 22 AWG Wire)

Top View

W24

Plugs into
VTMUX Board P18

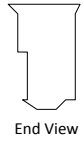
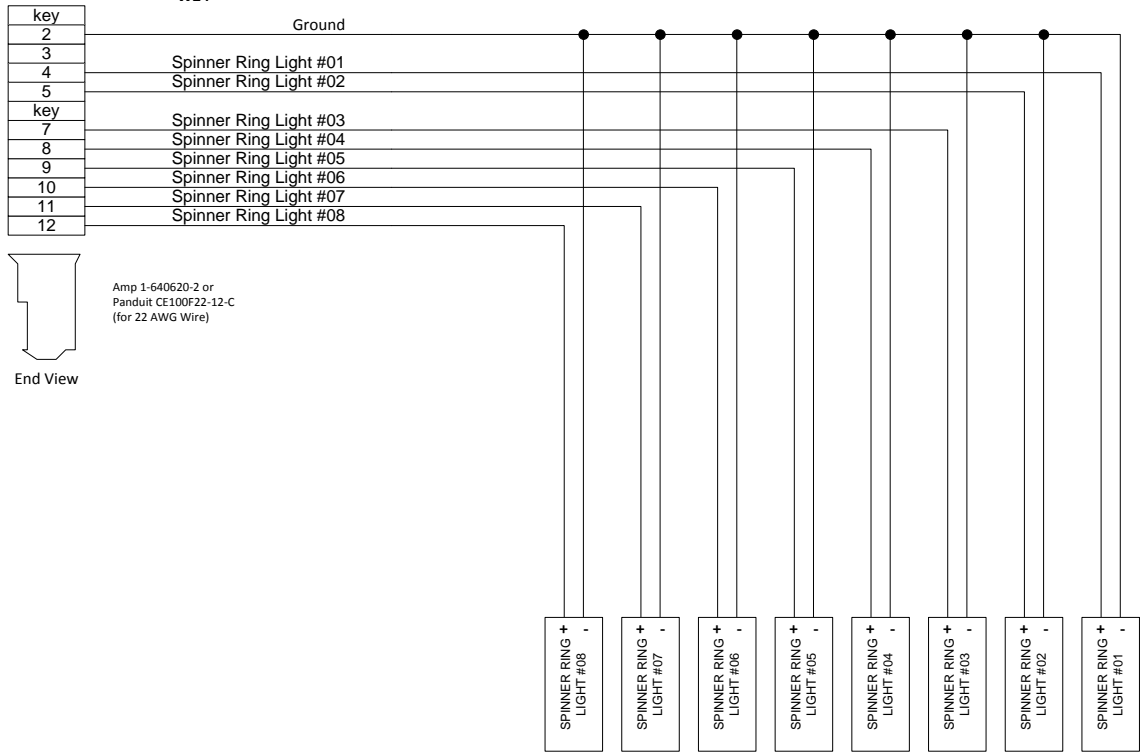

Amp 1-640620-2 or
Panduit CE100F22-12-C
(for 22 AWG Wire)

CONTROL MODULE (CONT)

W35 (VTMUX Board P29 to Large 8-Digit Display)

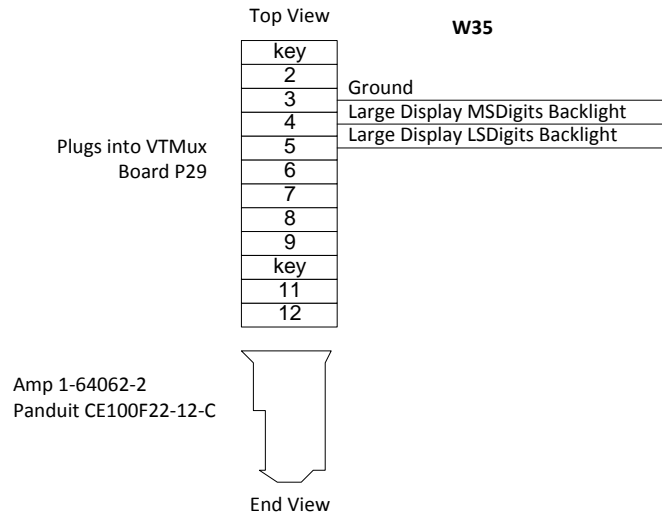

TICKET DISPENSING MODULE

W21 (VTMUX Board P22 to Start Button Lever Light, Coin Acceptor Light, Tickets Low LED1, 2, Coin Meter, Ticket LED Panel Strip, and Tickets1.2 Dispensing Lights)

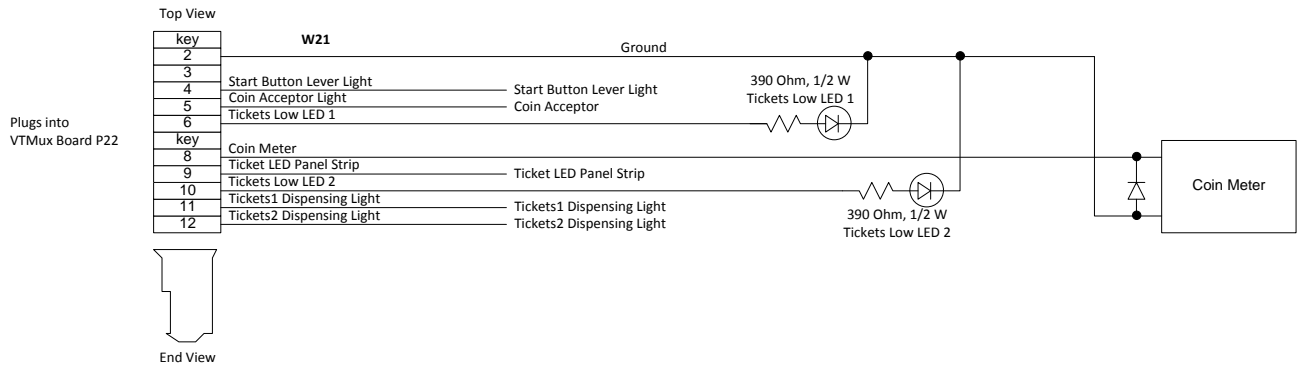

Amp 1-640620-2 or
Panduit CE100F22-12-C
(for 22 AWG Wire)

TICKET DISPENSING MODULE (CONT)

W15 (VTMUX Board P28 to Ticket Dispenser #1)

W5 (VTMUX Board P21 to Ticket Dispenser #2)

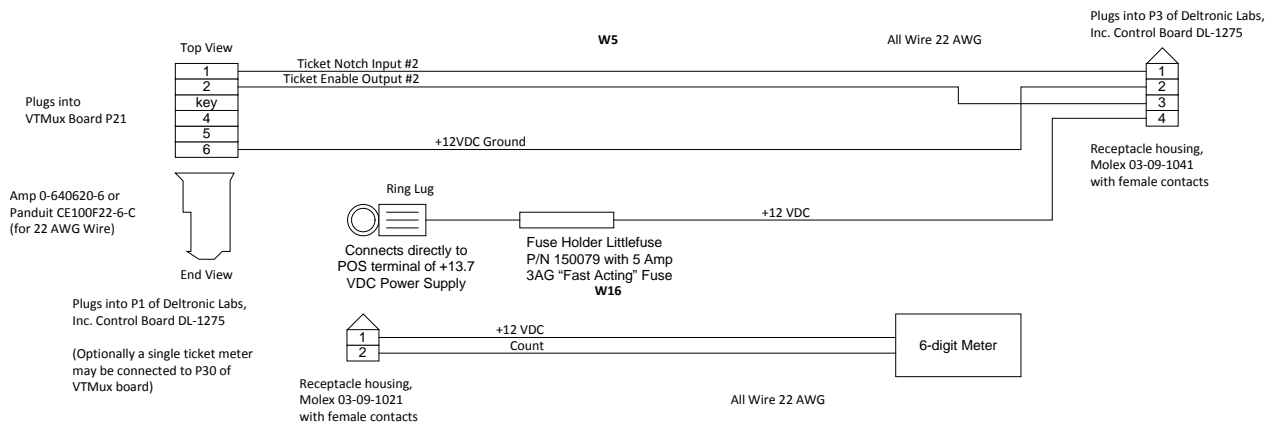
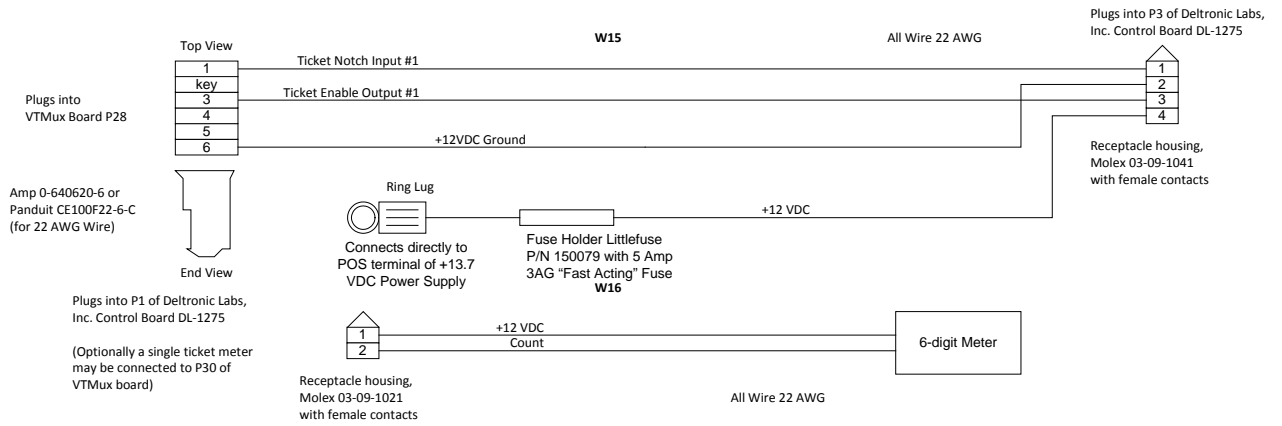

SPINNER MODULE

W34 (VTMUX Board P32 to Spinner Encoder J1)

Plugs into
VTMux Board
P32

W34

Plugs into
Spinner Encoder J1

Top View

1	VCC	1
key		2
key		3
4	Ground	4
5	Encoder Bit 1	5
6	Encoder Bit 2	6
7	Encoder Bit 3	7
8	Encoder Bit 4	8
9	Encoder Bit 5	9
10	Encoder Bit 6	10
11	Encoder Bit 7	11
12	Encoder Bit 8	12
		13
		14

Top View

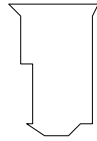

End View

Amp 1-640620-2 or
Panduit CE100F22-12-C
(for 22 AWG Wire)

SPINNER MODULE (CONT)

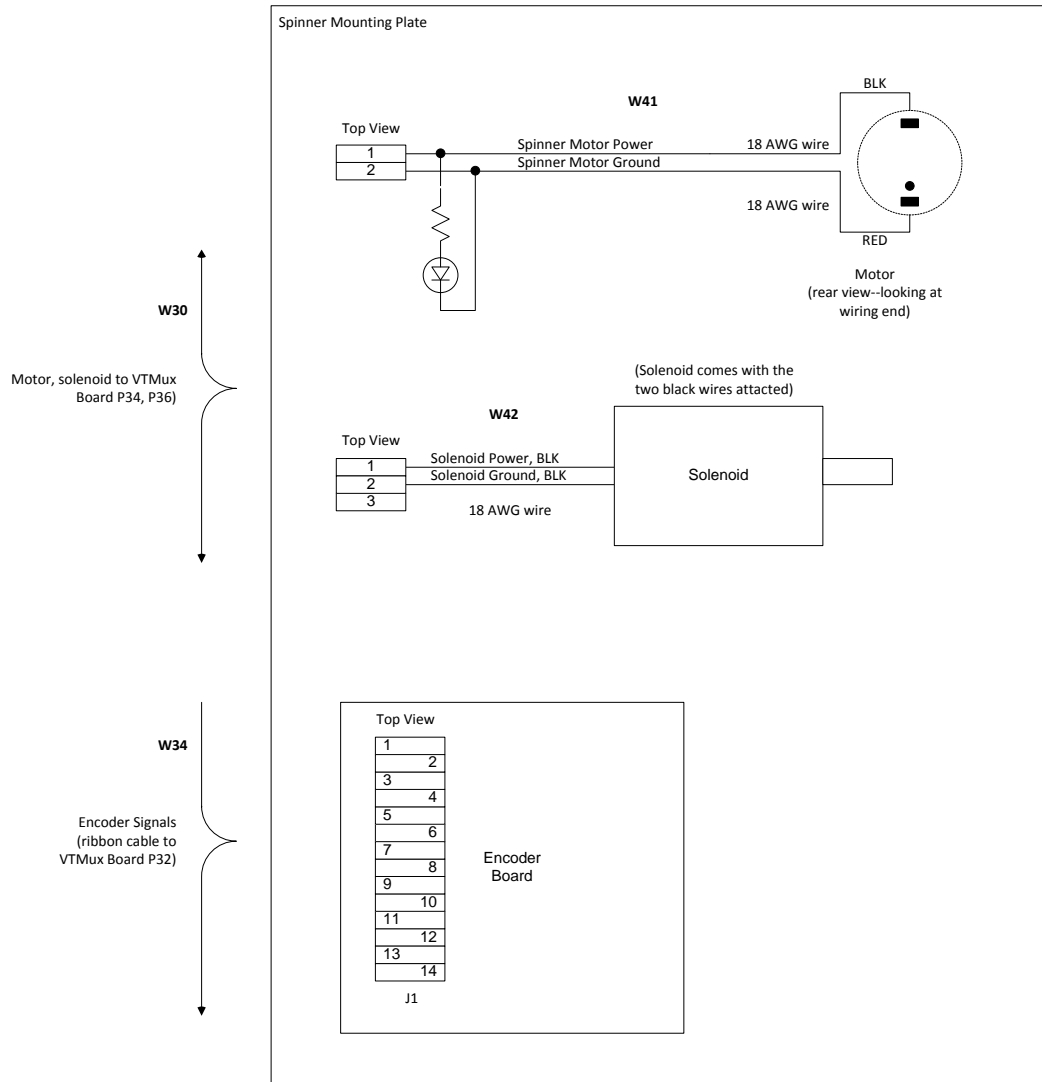

SPINNER MODULE (CONT)

W30 (VTMUX Board P34, 36 to Spinner Motor and Brake Solenoid)

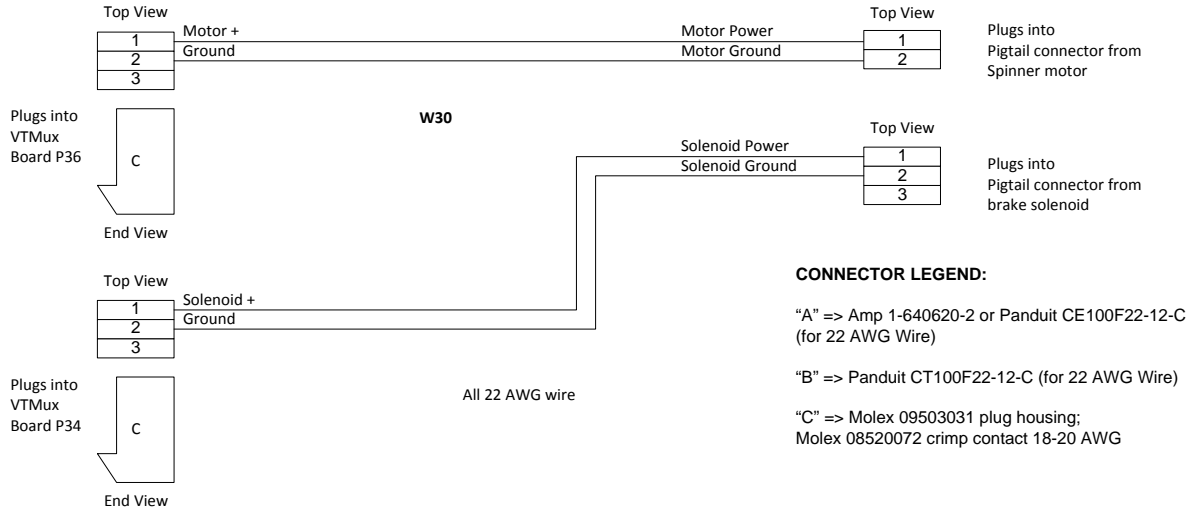

MISCELLANEOUS WIRING

W18 (VTMUX Board P3 to Program Mode Button and Coin Acceptor)

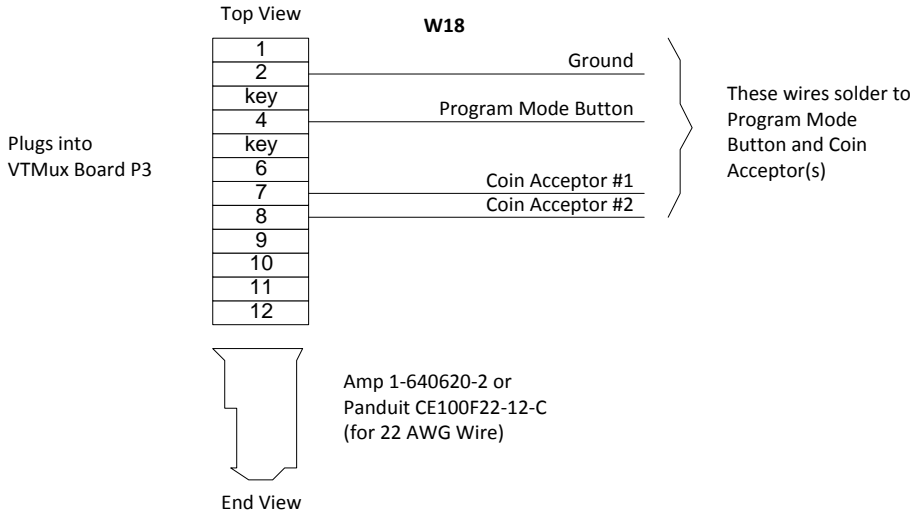

MISCELLANEOUS WIRING (CONT)

W45 (VTMUX Board P4 to Bill Acceptor)

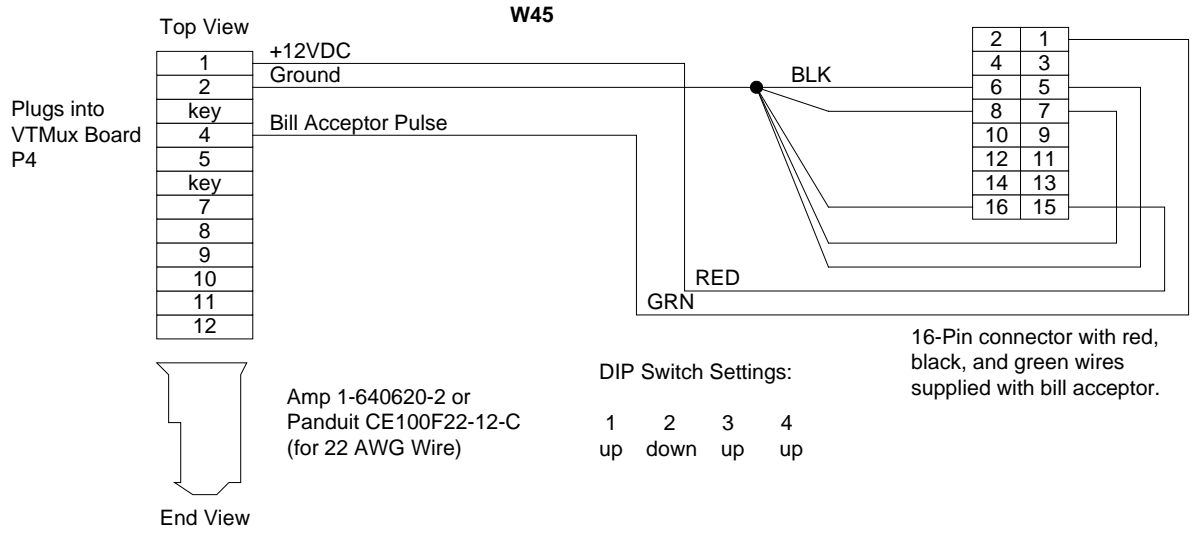

MISCELLANEOUS WIRING (CONT)

W35-37 (Speakers)

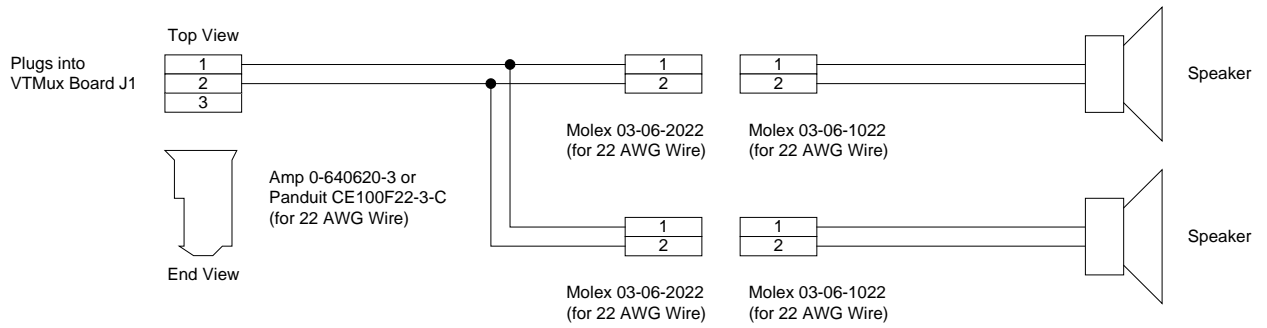

OPTO SENSORS WIRING

W84-87, 90, 91 (Slow Stop Lever, Start Lever, Tickets Out 1, 2, and Tickets Low 1, 2 Sensors)

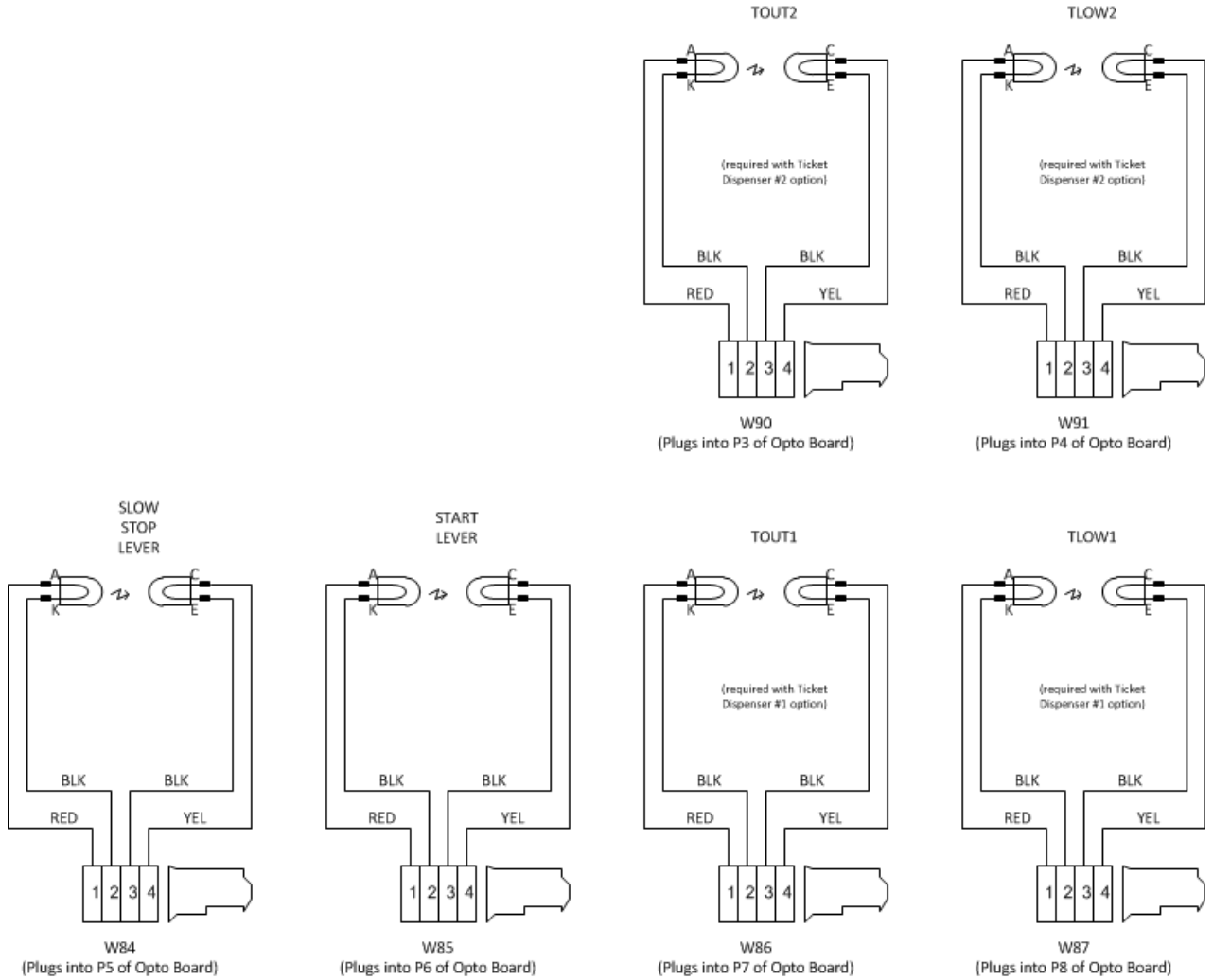

OPTO SENSORS WIRING (CONT)

W16 (VTMUX Board P12 to Opto Board P9)

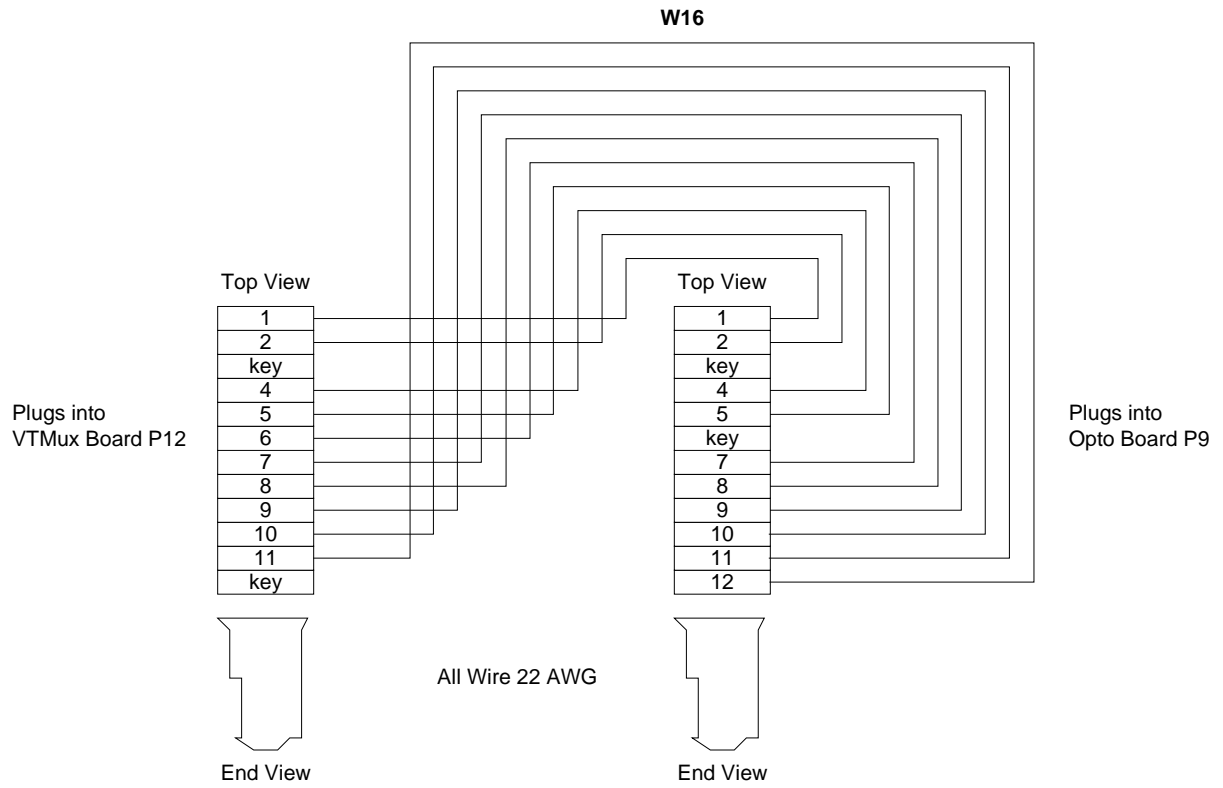

Display and Keypad Wiring

W7 (VTMUX Board P25 to Mixed Small/Large Displays)

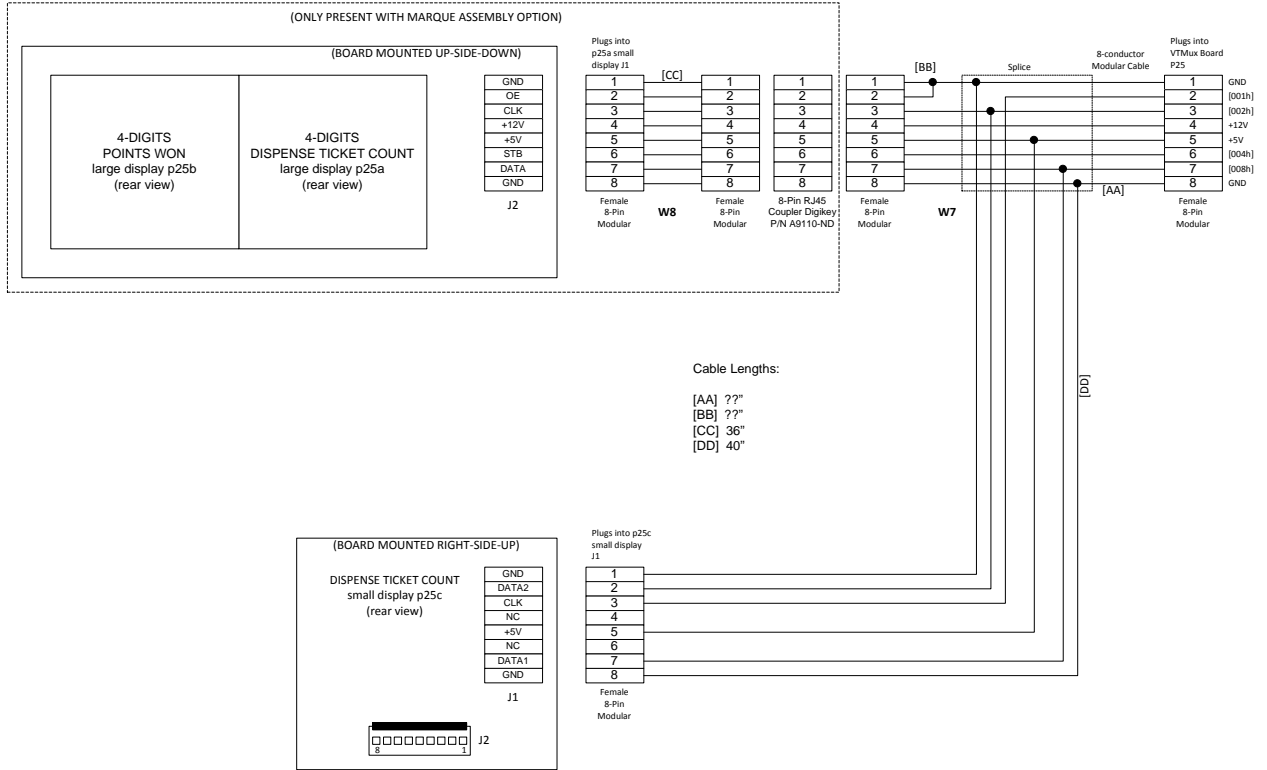

Cable Lengths:

[AA] ??"

[BB] ??"

[CC] 36"

[DD] 40"

(BOARD MOUNTED RIGHT-SIDE-UP)

DISPENSE TICKET COUNT
small display p25c
(rear view)

GND
DATA2
CLK
NC
+5V
NC
DATA1
GND

J1

□	□	□	□	□	□	□	□
8							1

J2

Plugs into p25c small display J1

1
2
3
4
5
6
7
8

Female 8-Pin Modular

Display and Keypad Wiring (cont)

W36, W37, W38 (VTMUX Board P26 to CONTROL PANEL Small 4-Digit Displays Wiring)

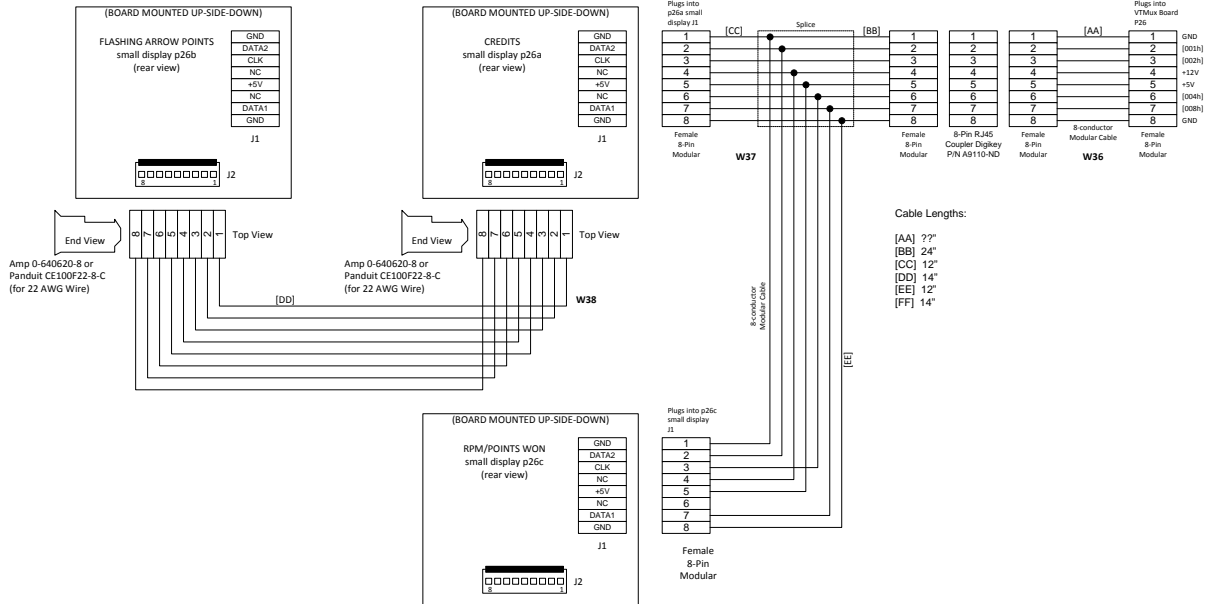

Display and Keypad wiring (cont)

W28, W29 (Keypad and Small Display Wiring)
W28 (VTMUX Board J2 to Keypad KEY)
W29 (Keypad GUMB1 to Small Display J2)

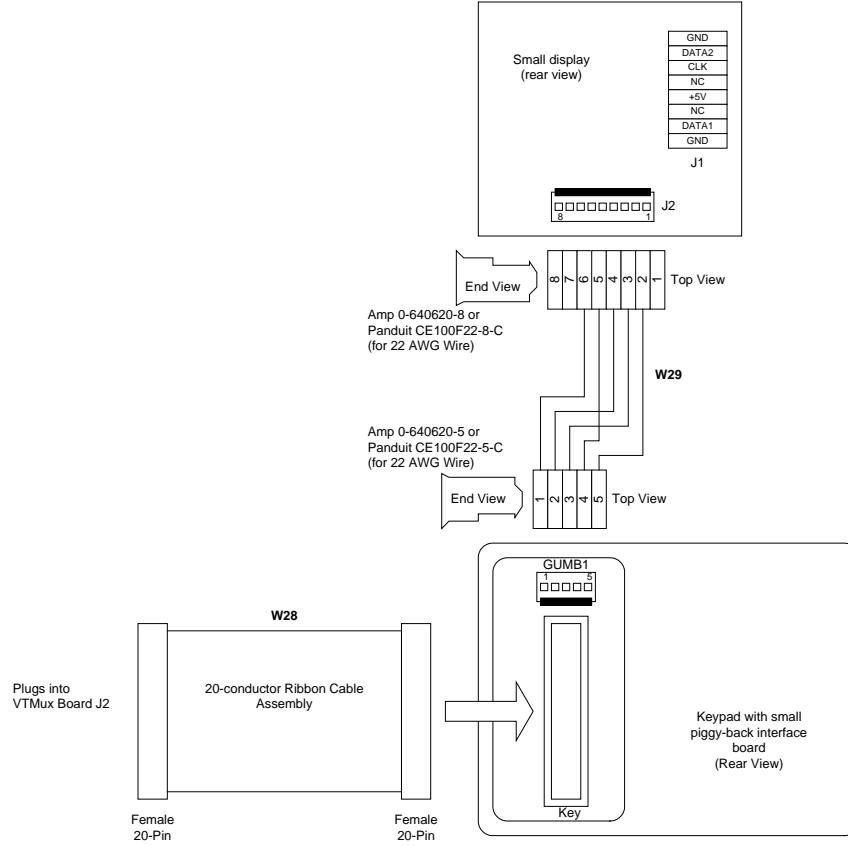

W1, W2, W3, W7 (13.7 VDC Power Supply and Grounds)

W1 (13.7 VDC Power Supply to VTMUX Board P19)

W2 (13.7 VDC Power Supply to VTMUX Board P43)

W3 (Chassis Ground)

W4 (Audio Ground)

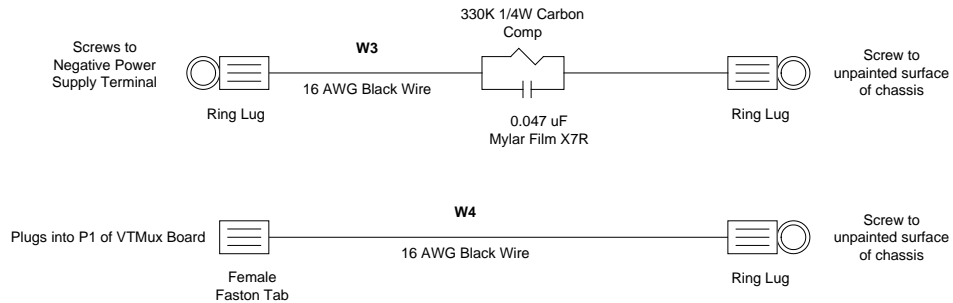
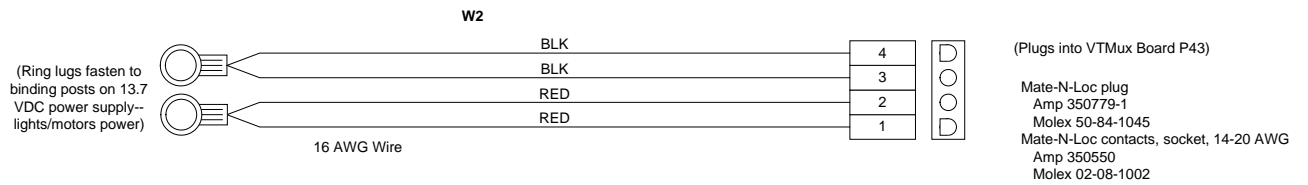
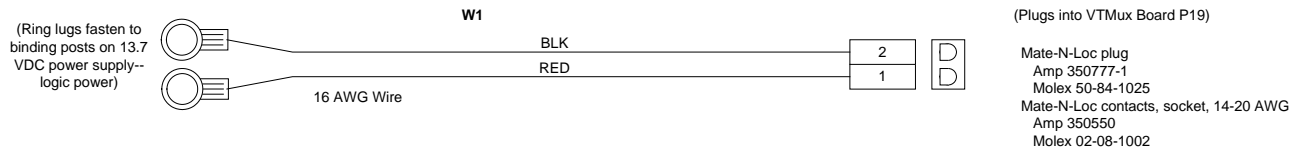

W101, W102, W109 (Protective Ground Wiring)

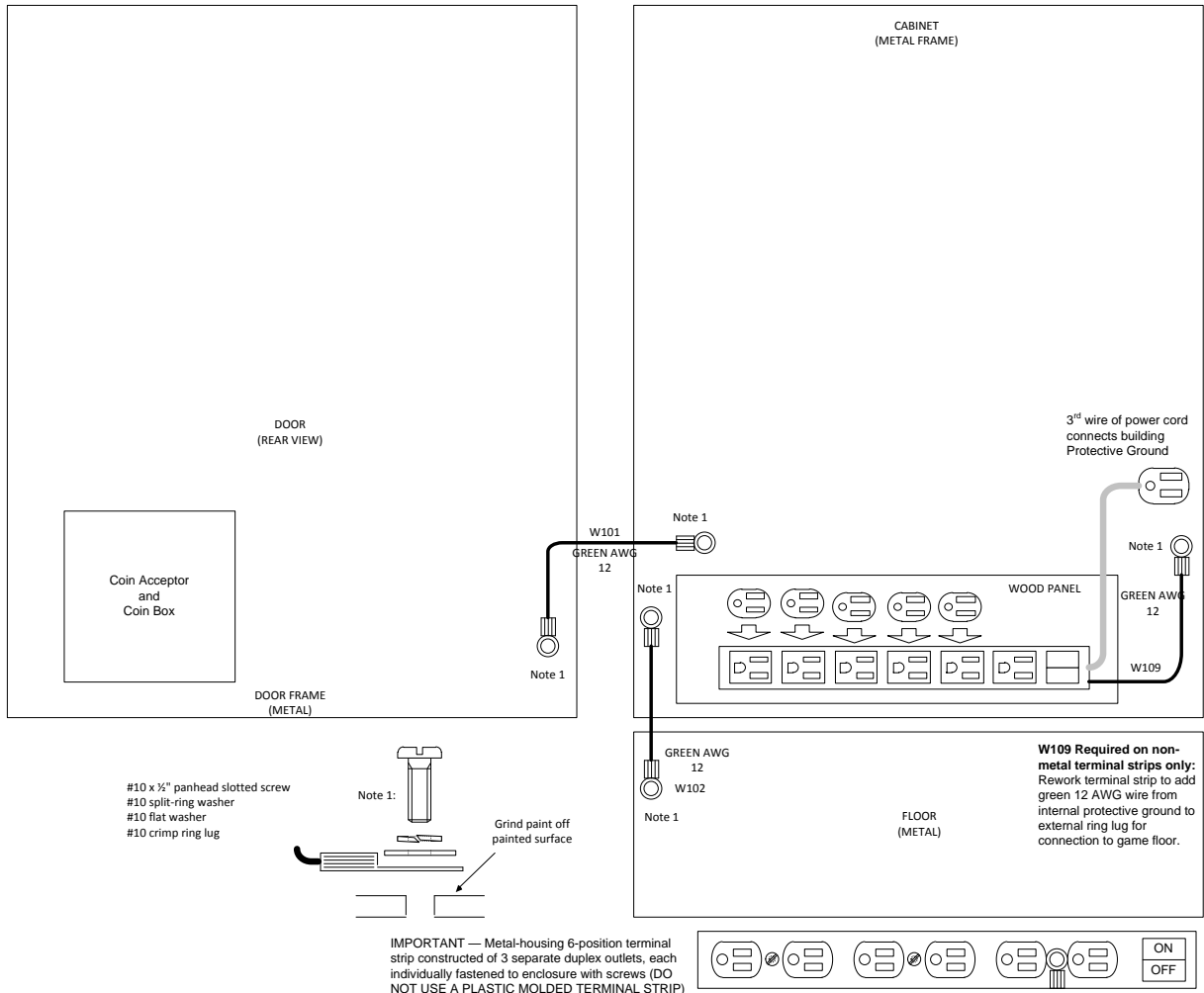

Appendix A—VTMUX Board Layout

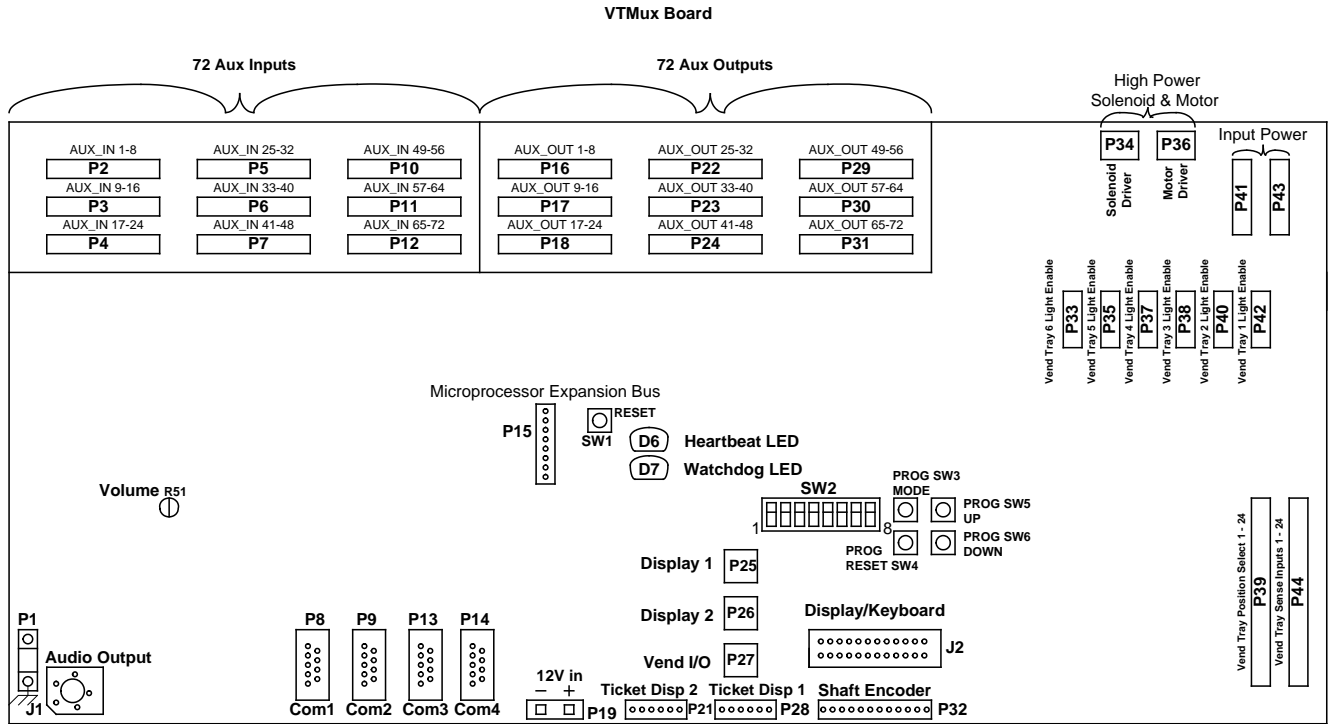

Appendix B—Opto Board Layout

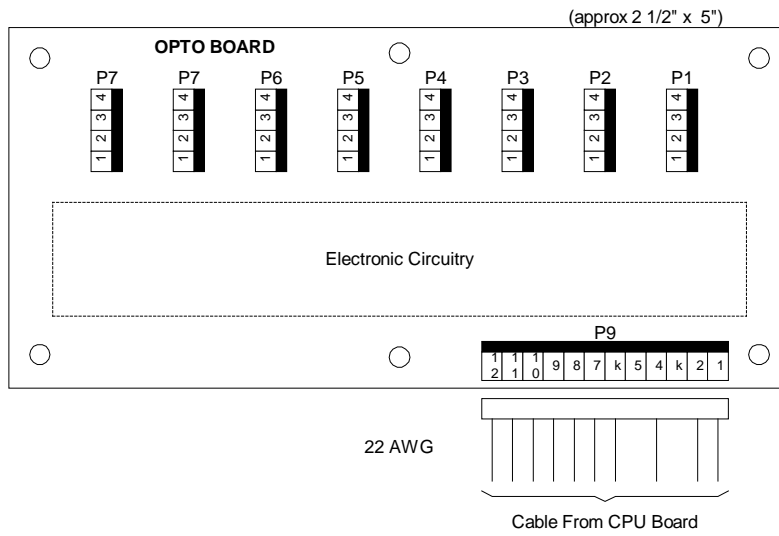

✓

Appendix C Troubleshooting Assistance

Troubleshooting Guide

Problem	Solution	Associated Program Step # (if applicable)
Game will not power up	<ul style="list-style-type: none"> • Verify 120 VAC power is present on cabinet power strips • Replace 13.7 VDC power supply 	<p>NA</p> <p>NA</p>
Pushbutton light does not illuminate	<ul style="list-style-type: none"> • Examine and replace any burned-out lamp • Measure low-voltage across terminals of lamp socket and if voltage not present when light should be on, check wiring harness • Measure low-voltage at output from VTMUX board and if voltage not present when light should be on, replace VTMUX board and retest 	<p>NA</p> <p>NA</p> <p>NA</p>
Game does not respond to pushing a flashing pushbutton	<ul style="list-style-type: none"> • Check number of coins required to play setting • Examine and replace any defective pushbutton • Look for low-voltage changes at VTMUX board input when pushbutton pushed and if voltage does not change, check wiring harness • Replace VTMUX board and retest 	<p>Step 30</p> <p>NA</p> <p>NA</p> <p>NA</p>
Does not respond when coin/token inserted	<ul style="list-style-type: none"> • Examine and replace any defective coin acceptor mechanism • Look for low-voltage changes at VTMUX board input when coin/token inserted and if voltage does not change, check wiring harness • Replace VTMUX board and retest 	<p>NA</p> <p>NA</p> <p>NA</p>
No sound	<ul style="list-style-type: none"> • Check VOLUME potentiometer on VTMUX board and turn clockwise to increase volume • Examine and replace any defective speaker • Check wiring harness • Replace VTMUX board and retest 	<p>NA</p> <p>NA</p> <p>NA</p> <p>NA</p>
Does not dispense tickets	<ul style="list-style-type: none"> • Clear ticket dispenser of any jammed tickets • Load tickets if empty • Try dispensing a ticket using diagnostic mode, if ticket does not dispense: <ul style="list-style-type: none"> ○ Check wiring harness ○ Replace ticket dispenser and retest ○ Replace VTMUX board and retest 	<p>NA</p> <p>NA</p> <p>Step 81</p> <p>NA</p> <p>NA</p>
4-digit display always blank or shows gibberish	<ul style="list-style-type: none"> • Replace 4-digit display and retest 	<p>NA</p>

Problem	Solution	Associated Program Step # (if applicable)
	<ul style="list-style-type: none"> • Replace VTMUX board and retest 	NA
	<ul style="list-style-type: none"> • Check wiring harness 	NA
Spinner light-ring does not illuminate	<ul style="list-style-type: none"> • Look for low-voltage changes at VTMUX board output when light-ring should be illuminated and if voltage does not change, replace VTMUX board and retest • Look for low-voltage changes at input to solid state relay when light-ring should be illuminated and if voltage does not change, check wiring harness • Look for 120 VAC voltage changes at output from solid state relay when light-ring should be illuminated: <ul style="list-style-type: none"> ○ If voltage does not change, replace solid state relay and retest ○ If voltage does change, replace light-ring and/or neon high-voltage transformer and retest (CAUTION— EXTREMELY DANGEROUS HIGH VOLTAGE) 	NA NA NA NA
Spinner does not spin	<ul style="list-style-type: none"> • Troubleshoot spinner motors 	Step 76
Spinner brake does not operate	<ul style="list-style-type: none"> • Troubleshoot spinner brakes 	Step 76
SOME spinners CONSISTENTLY give wrong POINTS	<ul style="list-style-type: none"> • Verify correct POINT programming: <ul style="list-style-type: none"> ○ Spinner #1 ○ Spinner #2 ○ Spinner #3 ○ Spinner #4 ○ Spinner #5 • Troubleshoot spinner boards and calibrate spinner(s) (requires access to spinner mechanism) • Troubleshoot spinner boards and spinner mechanism (does not require access to spinner mechanism, but does not allow calibration of spinner to TDC) 	Steps 100-115 Steps 200-215 Steps 300-315 Steps 400-415 Steps 500-515 Step 71-75 Steps 76
SOME spinners INTERMITTENTLY give wrong POINTS	<ul style="list-style-type: none"> • Troubleshoot spinners and spinner boards for intermittent problems 	Step 79
ALL spinners CONSISTENTLY give wrong POINTS	<ul style="list-style-type: none"> • Verify correct POINT programming: <ul style="list-style-type: none"> ○ Spinner #1 • Troubleshoot spinner boards and wiring harness for data bus jamming 	Steps 100-115 Step 79
SOME spinners CONSISTENTLY cause a JUMP to wrong spinner	<ul style="list-style-type: none"> • Verify correct POSITION TYPE programming: <ul style="list-style-type: none"> ○ Spinner #1 • Troubleshoot spinner boards and calibrate 	Steps 150-173

Problem	Solution	Associated Program Step # (if applicable)
	spinner(s) if required (requires access to spinner mechanism) <ul style="list-style-type: none"> • Troubleshoot spinner boards and spinner mechanism (does not require access to spinner mechanism, but does not allow calibration of spinner to TDC) 	Step 71-78 Steps 79

REPLACING SPINNER

Appendix D Replacing or Realigning Spinner Wheels

INSTRUCTIONS FOR

1. REPLACING A SPINNER'S ENCODER WHEEL OR
2. REALIGNING AND TIGHTENING ENCODER WHEEL

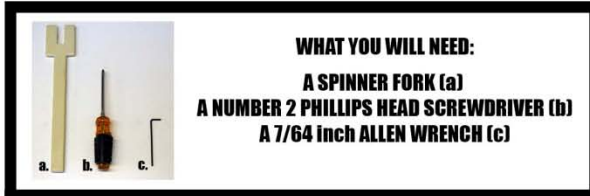

WHAT YOU WILL NEED:
A SPINNER FORK (a)
A NUMBER 2 PHILLIPS HEAD SCREWDRIVER (b)
A 7/64 inch ALLEN WRENCH (c)

STEP # 1:

Power game down. Detach any harnesses connected to the spinner. Loosen wing nuts shown and remove spinner assembly from game.

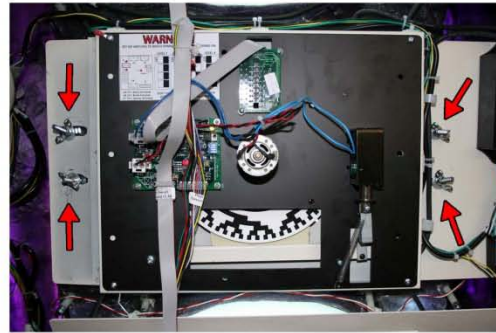

STEP # 2:

Using the 7/64 Allen Wrench, remove the two allen bolts that hold the ghost arrow to the pulley

STEP # 3

Using the # 2 phillips head screwdriver, remove the 4 screws which hold the black spinner assembly to the white main spinner bracket. Then remove the black spinner assembly from the white main spinner bracket

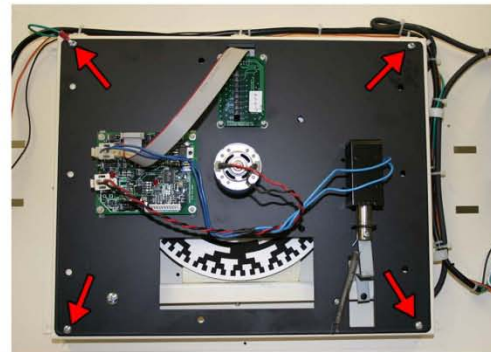

REPLACING OR REALIGNING SPINNER WHEEL

INSTRUCTIONS FOR REPLACING A SPINNER'S ENCODER WHEEL

STEP # 4

(SKIP STEP IF YOU ARE ONLY REALIGNING AND TIGHTENING)

Using the # 2 screwdriver, remove the set screw that holds the brake arm. This screw is next to the brake spring.

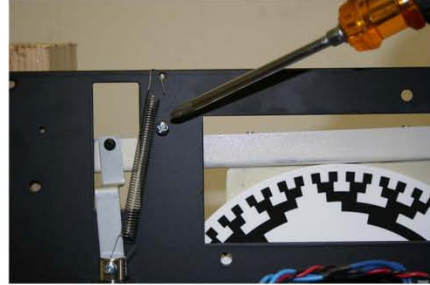

STEP # 5

(SKIP STEP IF YOU ARE ONLY REALIGNING AND TIGHTENING)

Turn the assembly around and loosen the set screw which holds the pulley to the motor shaft. Then, lift the brake arm and slide the pulley and encoder disc off.

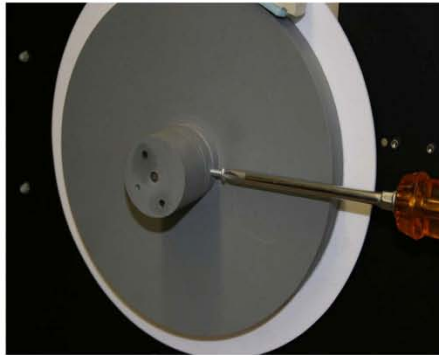

STEP # 6

(most critical step)

Slide the spinner fork against the motor shaft. Lower the pulley and encoder disc onto the motor shaft so that it rests gently upon the fork. This will give you the proper spacing. Then, tighten the set screw loosened in Step #6, and remove the spinner fork.

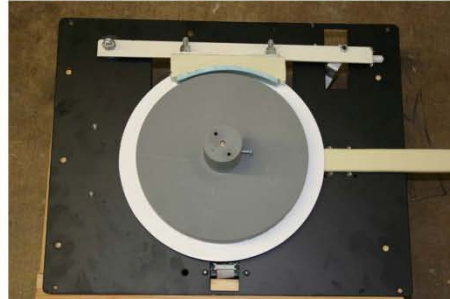

NOTE: UNITS BUILT AFTER 3/01/07 HAVE A NOTCH CUT INTO THE MOTOR SHAFT THAT THE SET SCREW TIGHTENS INTO. IF YOUR UNIT IS DATED AFTER 03/01/07 - THE SET SCREW MUST BE TIGHTENED INTO THIS NOTCH TO FUNCTION.

REPLACING OR REALIGNING SPINNER WHEEL

STEP # 7

Take a moments now to observe the new assembly. The encoder disc should not be touching the white spacers near the motor shaft . The disc should be seated about an 1/8" away from these spacers.

STEP # 8

Reattach the black spinner assembly to the white main spinner bracket . Then install the whole assembly back into the game

RECALIBRATION PROCEDURE

Using the keypad - go to the step associated with the recently replaced spinner

**Step #71 = Spinner #1
Step # 72 = Spinner #2
Step #73 = Spinner #3
Step #74 = Spinner #4
Step #75 = Spinner # 5**

**TO ENTER PROGRAM MODE - take the keypad and hold in the # and * buttons until the keypad display goes blank. Push 1-1 on the keypad - you are now in program mode.
Hold the * button down and push either 71, 72, 73, 74, or 75**

By lightly tapping the FAST STOP BUTTON, move the spinner arrow until it reaches the 12 o'clock position, where there should be an alignment line. Once the point of the arrow is at 12 o'clock - hit the flashing START BUTTON. Your spinner is no recalibrated.

**If you have any questions during your installation - feel free to call our technical service department directly at
(818) 775 - 9374
or, if a technician is not immediately available, please call
(818) 581 - 1772**

Appendix E

TECHNICAL ASSISTANCE

Most distributors provide technical assistance for the products they sell. If your distributor cannot solve your problem, assistance can be obtained through Five Star Redemption. Call (818) 773-6057 extension 232 between the hours of 8:00 AM and 4:00 PM Pacific time, Monday through Friday, and ask for the service department.

Please have the following information available:

1. Type of Game
2. Serial Number
3. Distributor's Name
4. Description of Problem

The service technician may ask you to perform some tests on your machine, so it is preferable to call from the game's location if possible.

Five Star Redemption
ADDRESS AND TELEPHONE NUMBERS

8803 SHIRLEY AVENUE
NORTHRIDGE, CA 91324
(818) 773-6057 FAX (818) 773-6064

PARTS DEPARTMENT OPTION 1

TECHNICAL SUPPORT OPTION 2

SALES DEPARTMENT OPTION 3